

**BOE****PROPRIETARY NOTE**

THIS SPECIFICATION IS THE PROPERTY OF BOE FZ AND SHALL NOT BE REPRODUCED OR COPIED WITHOUT THE WRITTEN PERMISSION OF BOE FZ AND MUST BE RETURNED TO BOE FZ UPON ITS REQUEST

**DV550QUM-N10****Preliminary Product Specification****P1****FUZHOU BOE OPTOELECTRONICS TECHNOLOGY Co.,LTD**

SPEC. NUMBER  
S8-65-8D-080

PRODUCT GROUP  
TFT-LCD

P1

ISSUE DATE  
2019/08/22

PAGE  
1 OF 40

DAS-RD-2019028-O

A4(210 X 297)

**BOE****PRODUCT GROUP**

REV

ISSUE DATE

Customer SPEC

P1

2019/08/22

**REVISION HISTORY** preliminary specification Final specification

Revision No.	Page	Description of changes	Date	Prepared
P0	-	Initial Release	2019/08/14	Tang Guichun
P1	11	Update LED Light bar Unit Characteristics	2019/08/22	Tang Guichun

SPEC. NUMBER  
S8-65-8D-080SPEC. TITLE  
DV550QUM-N10 Preliminary Product Specification P1PAGE  
2 OF 40

DAS-RD-2019028-O

A4(210 X 297)

**BOE****PRODUCT GROUP**

REV

ISSUE DATE

Customer SPEC

P1

2019/08/22

**Contents**

No.	Item	Page
1.0	GENERAL DESCRIPTION	4
2.0	ABSOLUTE MAXIMUM RATINGS	6
3.0	ELECTRICAL SPECIFICATIONS	7
4.0	INTERFACE CONNECTION	15
5.0	SIGNAL TIMING WAVEFORMS OF INTERFACE SIGNAL	23
6.0	SIGNAL TIMING SPECIFICATION	25
7.0	OPTICAL SPECIFICATION	28
8.0	MECHANICAL CHARACTERISTICS	31
9.0	RELIABILITY TEST	32
10.0	HANDLING & CAUTIONS	33
11.0	PRODUCT SERIAL NUMBER	34
12.0	PACKING	35
13.0	APPENDIX	37

SPEC. NUMBER  
S8-65-8D-080SPEC. TITLE  
DV550QUM-N10 Preliminary Product Specification P1PAGE  
3 OF 40

DAS-RD-2019028-O

A4(210 X 297)

**BOE****PRODUCT GROUP**

REV

ISSUE DATE

Customer SPEC

P1

2019/08/22

## 1.0 GENERAL DESCRIPTION

### 1.1 Introduction

DV550QUM-N10 is a color active matrix TFT LCD module using amorphous silicon TFT's (Thin Film Transistors) as an active switching device. This module has a 54.64 inch diagonally measured active area with UHD resolutions (3840 horizontal by 2160 vertical pixel array). Each pixel is divided into RED, GREEN, BLUE dots which are arranged in island and this module can display 1.07G colors. The TFT-LCD panel used for this module is adapted for a low reflection and higher color type.

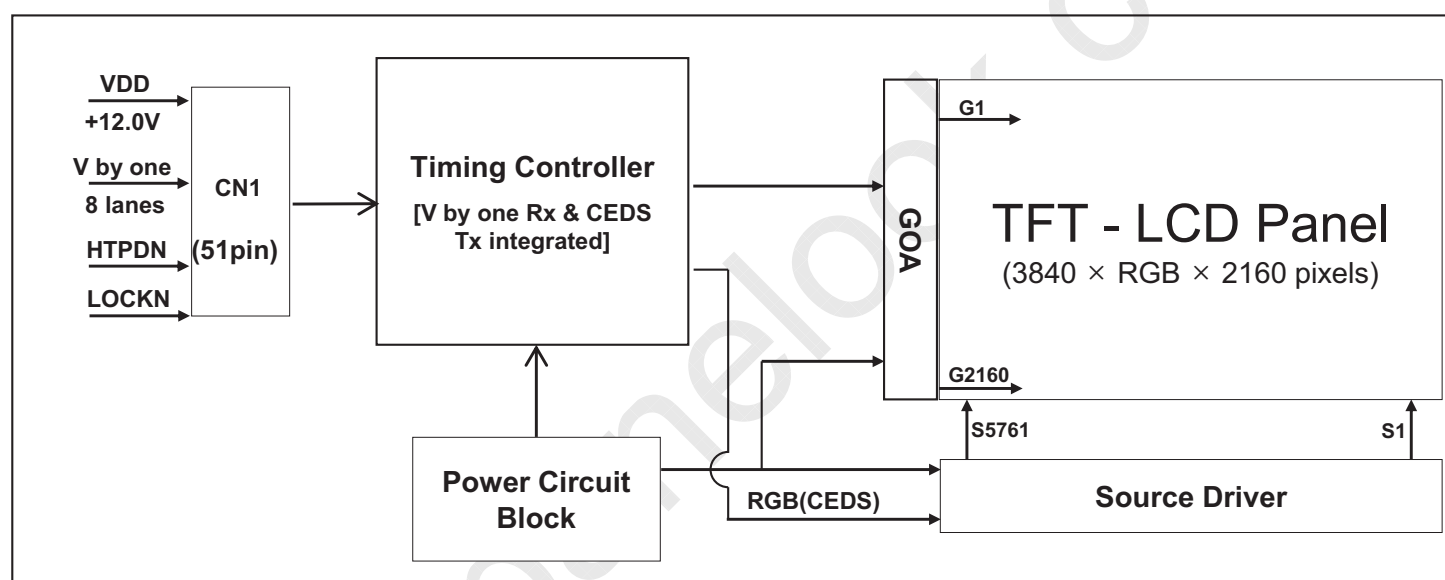

### 1.2 Features

- V by one interface with 8 lanes
- High-speed response
- Low color shift image quality
- 8-bit + FRC color depth, display 1.07G colors
- High luminance and contrast ratio, low reflection and wide viewing angle
- DE (Data Enable) only mode
- ADS technology is applied for high display quality
- RoHS compliant
- Horizontal and Perpendicular compatibility (Vertical Spec: Rotate 90° clockwise facing the LCM front)

SPEC. NUMBER  
S8-65-8D-080

SPEC. TITLE  
DV550QUM-N10 Preliminary Product Specification P1

PAGE  
4 OF 40

DAS-RD-2019028-O

A4(210 X 297)

**BOE****PRODUCT GROUP**

REV

ISSUE DATE

Customer SPEC

P1

2019/08/22

**1.0 GENERAL DESCRIPTION****1.3 Application**

- Home Alone Multimedia TFT-LCD TV
- Display Terminals for Control System
- Ultra High Definition TV(UHD TV)
- AV application Products

**1.4 General Specification**

&lt; Table 1. General Specifications &gt;

Parameter	Specification	Unit	Remark
Active area	1209.6(H) × 680.4(V)	mm	
Number of pixels	3840*(RGB)*2160	pixels	
Pixel pitch	315(H) × 315(V)	μm	
Pixel arrangement	Pixels RGB Island		
Display colors	1.07G (8bits + FRC )	colors	
Luminance, White	Min720, Typ. 800	nit	
Viewing Angle (CR>10)	Viewing angle free ( R/L 178 (Typ.), U/D 178 (Typ.))		
Display mode	Transmission mode, Normally Black		
Open Cell Transmittance	5.4	%	At center point with BOE BLU
Weight	15	Kg	Module
Power Consumption	Total: Typ:120.86 Max:153.51 Logic: Typ:12 Max:36 BLU: Typ:108.86 Max:117.51	Watt	
Surface Treatment	Haze 1% , 3H, Anti-Glare Layer (for Front and Rear Polarizer)		
Remark	Horizontal and Perpendicular compatibility(Vertical Spec:Rotate 90° clockwise facing the LCM front)		

SPEC. NUMBER  
S8-65-8D-080SPEC. TITLE  
DV550QUM-N10 Preliminary Product Specification P1PAGE  
5 OF 40

DAS-RD-2019028-O

A4(210 X 297)

**BOE****PRODUCT GROUP**

REV

ISSUE DATE

Customer SPEC

P1

2019/08/22

**2.0 ABSOLUTE MAXIMUM RATINGS**

The followings are maximum values which, if exceed, may cause faulty operation or damage to the unit. The operational and non-operational maximum voltage and current values are listed in Table 2.

&lt; Table 2. Absolute Maximum Ratings &gt;

[VSS=GND=0V]

Parameter	Symbol	Min.	Max.	Unit	Remark
Power Supply Voltage	VDD	VSS-0.3	13.2	V	Ta = 25 °C
Backlight Input Voltage(LED Bar Circuit)	VBL	104.4	122.4	VRMS	
Operating Temperature	T <sub>OP</sub>	0	+50	°C	Note 1
Storage Temperature	T <sub>SUR</sub>	-20	+60	°C	
	T <sub>ST</sub>	-20	+60	°C	
Operating Ambient Humidity	Hop	10	80	%RH	
Storage Humidity	Hst	10	80	%RH	

Note 1 : Temperature and relative humidity range are shown in the figure below.

Note 2 : Wet bulb temperature should be 39 °C max. and no condensation of water.

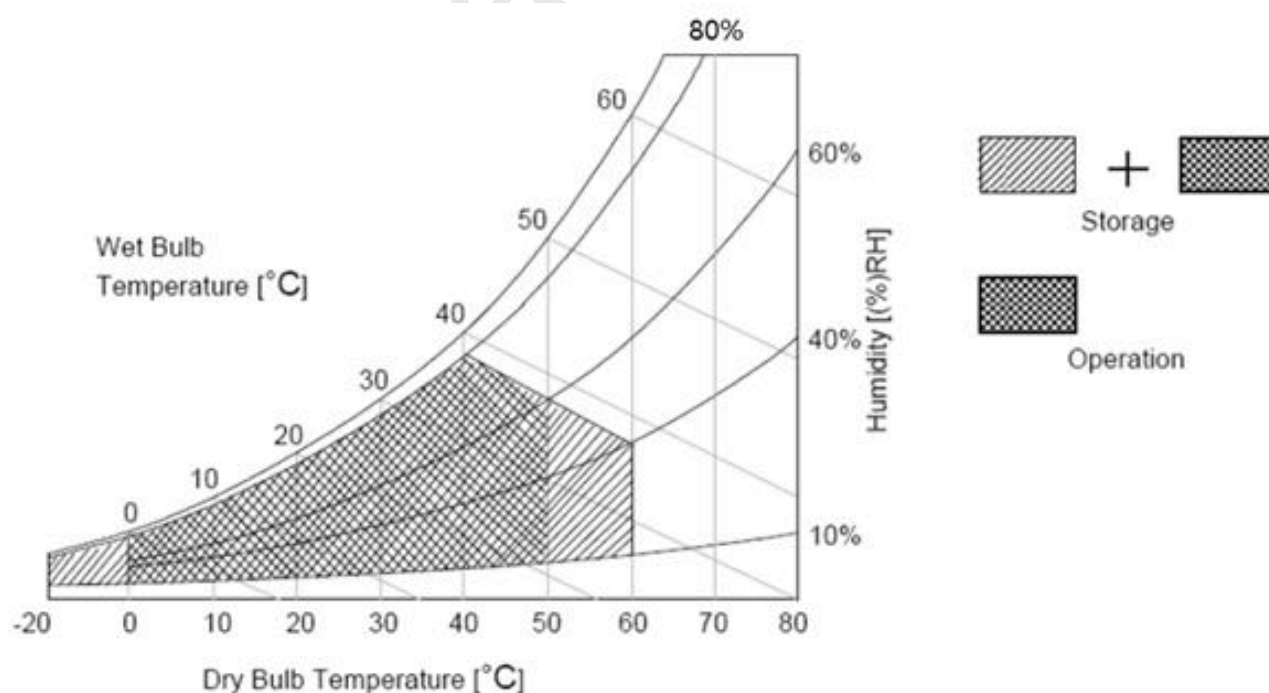

SPEC. NUMBER  
S8-65-8D-080

SPEC. TITLE  
DV550QUM-N10 Preliminary Product Specification P1

PAGE  
6 OF 40

DAS-RD-2019028-O

A4(210 X 297)

**BOE****PRODUCT GROUP**

REV

ISSUE DATE

Customer SPEC

P1

2019/08/22

**3.0 ELECTRICAL SPECIFICATIONS****3.1 TFT LCD Open Cell**

&lt; Table 3. Open Cell Electrical Specifications &gt;

[Ta =25±2 °C]

Parameter	Symbol	Values			Unit	Remark	
		Min	Typ	Max			
Power Supply Input Voltage	VDD	10.8	12	13.2	Vdc		
Power Supply Ripple Voltage	VRP	-	-	600	mV		
Power Supply Current	IDD	-	1	3	A	Note 1	
Power Consumption	PDD		12	36	Watt		
Rush current	IRUSH	-	-	10	A	Note 2	
V by One Interface	Differential Input High Threshold Voltage	VLVTH	-	-	+50	mV	
	Differential Input Low Threshold Voltage	VLVTL	-50	-	-	mV	
	Common Input Voltage	VLVC	-	-	-	V	
	Terminating Resistor	Rt	90	100	110	ohm	
CMOS Interface	Input High Threshold Voltage	VIH	2.0	-	3.3	V	
	Input Low Threshold Voltage	VIL	0	-	0.8	V	

Note 1 : The supply voltage is measured and specified at the interface connector of LCM.

The current draw and power consumption specified is for VDD=12.0V.

a) Typ: Mosaic 7X5(L0/L255)

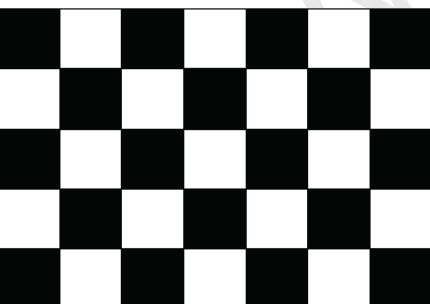

b) Max : Vertical Sub Line(L255)



c) Flicker Test Pattern

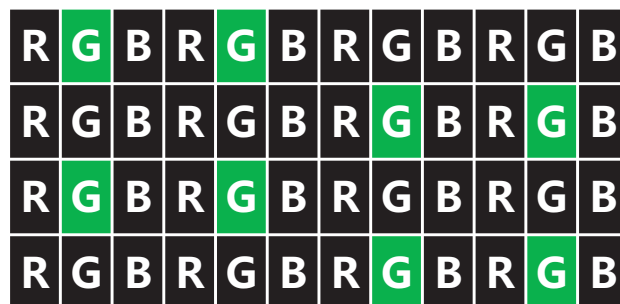

Note 2 : The duration of rush current is about 2ms and rising time of Power Input is 1ms(min).

SPEC. NUMBER  
S8-65-8D-080SPEC. TITLE  
DV550QUM-N10 Preliminary Product Specification P1PAGE  
7 OF 40

DAS-RD-2019028-O

A4(210 X 297)

**BOE****PRODUCT GROUP**

REV

ISSUE DATE

Customer SPEC

P1

2019/08/22

**3.0 ELECTRICAL SPECIFICATIONS****3.2 IC Characteristics**

&lt; Table 4. TCON Characteristics &gt;

Parameter	Symbol	Values			Unit	Remark
		Min	Typ	Max		
TCON Surface Temperature	$T_{TS}$	-	-	110	°C	Note

Note 1 : Any point on the TCON surface must be less than 110 °C under any conditions.

Note 2 : This test condition is based on BOE module.

&lt; Table 5. Driver Characteristics &gt;

Parameter	Symbol	Values			Unit	Remark
		Min	Typ	Max		
Driver Surface Temperature	$T_{DS}$	-	-	125	°C	Note

Note 3 : Any point on the driver surface must be less than 125 °C under any conditions.

Note 4: This test condition is based on BOE module.

&lt; Table 6. PMIC Characteristics &gt;

Parameter	Symbol	Values			Unit	Remark
		Min	Typ	Max		
PMIC Surface Temperature	$T_{PS}$	-	-	100	°C	Note

Note 5 : Any point on the PMIC surface must be less than 100 °C under any conditions.

Note 6: This test condition is based on BOE module.

SPEC. NUMBER  
S8-65-8D-080SPEC. TITLE  
DV550QUM-N10 Preliminary Product Specification P1PAGE  
8 OF 40

DAS-RD-2019028-O

A4(210 X 297)



**BOE****PRODUCT GROUP**

REV

ISSUE DATE

Customer SPEC

P1

2019/08/22

**3.0 ELECTRICAL SPECIFICATIONS****3.3 VCOM I2C Bus Format****Step1 Reset**

\*Device Address is 0x74 or 0x75(7Bits)

S	Slave Address	W	A	Index	Address 0	A	Control Byte	A	P
	<u>1 1 1 0 1 0 0 0</u>				<u>0 0 0 0 0 0 0 0</u>		<u>0 0 0 1 0 0 1 0</u>		
	0xE8				0x00		0x12		
	Device Address + W				Control Address		Reset + OUT EN		

**Step2 Read VCOM**

\*Data = 7Bits

S	Slave Address	W	A	Index	Address 1	SR	Slave Address	R	A	DATA 0/1	NA	P
	<u>1 1 1 0 1 0 0 0</u>				<u>0 0 0 0 0 0 0 1</u>		<u>1 1 1 0 1 0 0 1</u>			<u>X X X X X X X X</u>		
	0XE8				0X01		0XE9					
	Device address + W				VCOM Address		Device address + R			Data		

**Step3 Adjust VCOM**

\*DVCOM= 8Bits

S	Slave Address	W	A	Index	Address 1	A	DVCOM	A	P
	<u>1 1 1 0 1 0 0 0</u>				<u>0 0 0 0 0 0 0 1</u>		<u>0000000X~1111111X</u>		
	0XE8				0X01		0x00~0xFF		
	Device address + W				VCOM Address		VCOM value		

**Step4 Write VCOM**

S	Slave Address	W	A	Index	Address 1	A	Control Byte  (0x02)	A	P
	<u>1 1 1 0 1 0 0 0</u>				<u>0 0 0 0 0 0 0 0</u>		<u>0 0 0 0 1 0 1 0</u>		
	0xE8				0x00		0X0A		
	Device Address + W				Control Address		Write DAC to NVM + OUT_EN		

**Step5 Reset**

\*Device Address is 0x74 or 0x75(7Bits)

S	Slave Address	W	A	Index	Address 0	A	Control Byte	A	P
	<u>1 1 1 0 1 0 0 0</u>				<u>0 0 0 0 0 0 0 0</u>		<u>0 0 0 1 0 0 1 0</u>		
	0xE8				0x00		0x12		
	Device Address + W				Control Address		Reset + OUT_EN		

SPEC. NUMBER

S8-65-8D-080

SPEC. TITLE

DV550QUM-N10 Preliminary Product Specification P1

PAGE

9 OF 40

DAS-RD-2019028-O

A4(210 X 297)

**BOE****PRODUCT GROUP**

REV

ISSUE DATE

Customer SPEC

P1

2019/08/22

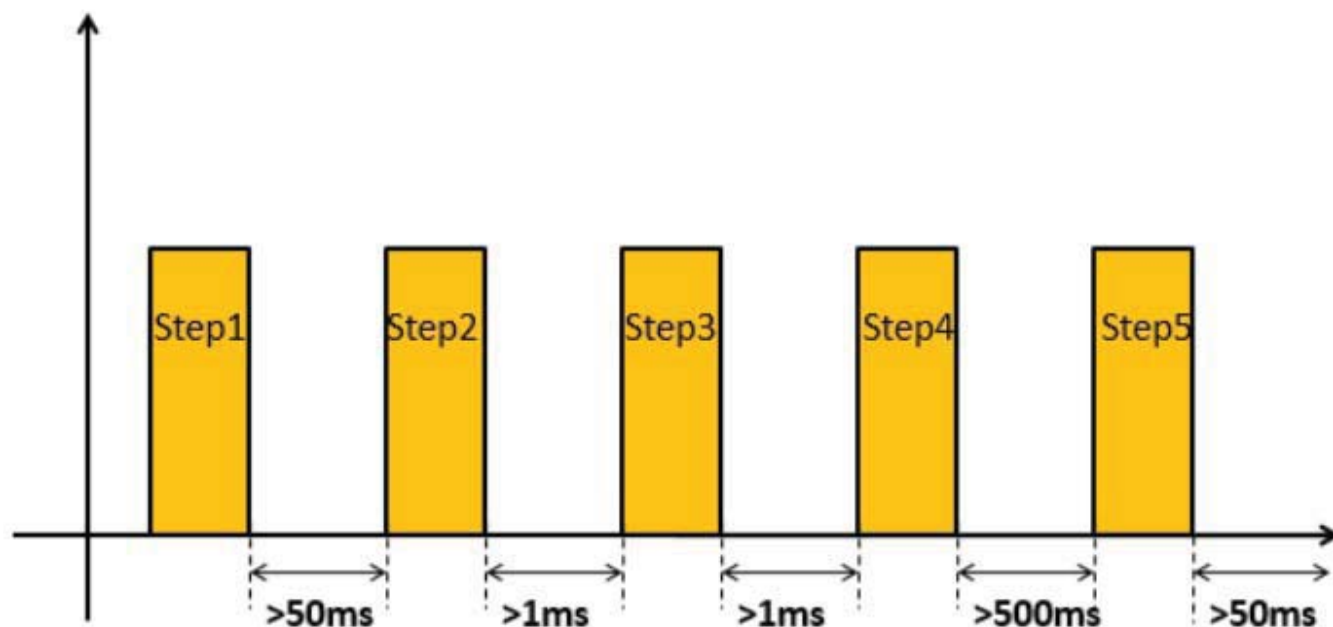
**3.0 ELECTRICAL SPECIFICATIONS****3.4 Interval of step to step**

SPEC. NUMBER  
S8-65-8D-080

SPEC. TITLE  
DV550QUM-N10 Preliminary Product Specification P1

PAGE  
10 OF 40

**BOE****PRODUCT GROUP**

REV

ISSUE DATE

Customer SPEC

P1

2019/08/22

**3.0 ELECTRICAL SPECIFICATIONS****3.5 Backlight Module**

&lt; Table 7. LED LIGHTBAR UNIT CHARACTERISTICS &gt; [Ta = 25 ± 2 °C]

Parameter	Symbol	Min.	Typ.	Max.	Unit	Remarks
LED Forward Voltage	V	104.4	113.4	122.4	V	-
LED Forward Current	I	-	880		mA	-
LED Power Consumption	W	91.9	99.8	107.8	W	-
LED Life-Time	L	50,000	-	-	Hour	Note 1

Note1 :The lifetime is defined as the time which luminance of the LED decays to 50% compared to the initial value, Operating condition: Continuous operating at Ta = 25 ± 2°C

**-LED Bar Block Diagram**

LED Numbers: 2bar / BLU

Total : 144LED / BLU

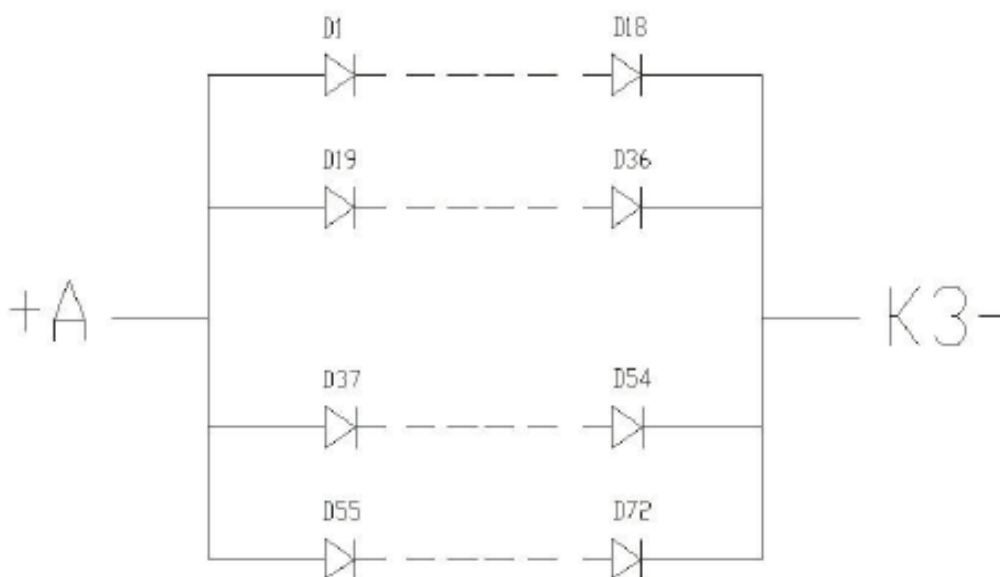

SPEC. NUMBER  
S8-65-8D-080

SPEC. TITLE  
DV550QUM-N10 Preliminary Product Specification P1

PAGE  
11 OF 40

**BOE****PRODUCT GROUP**

REV

ISSUE DATE

Customer SPEC

P1

2019/08/22

**3.0 ELECTRICAL SPECIFICATIONS****3.6 LED Constant Current Source**

This DC-DC LED Inverter was developed for LCD back lighting system with lighting use LED.

**(1) Pin Assignments**

< Table 8. Pin Definition of LED Constant Current Source >

Input connector : CN1			
Pin No.	Symbol	Description	Parameter
1,2,3,4,5	+24V	Supply voltage/	22~26V
6,7,8,9,10	GND	Ground	0 V
11,14	NC		
12	N/F	Standby/Operation	On =1.5-5.0V Off=0-0.5V
13	ADJ	Dimming control	0V=Brightness Max 5V=Brightness Min
Output socket CN2.3			
Pin No.	Symbol	Description	Parameter
1	OUT+	Output voltage	60-185V
2	OUT-	Ground	0

The above output parameters are determined according to the optical requirement. The products are not intended for use in systems in which failures of product could result in personal injury.

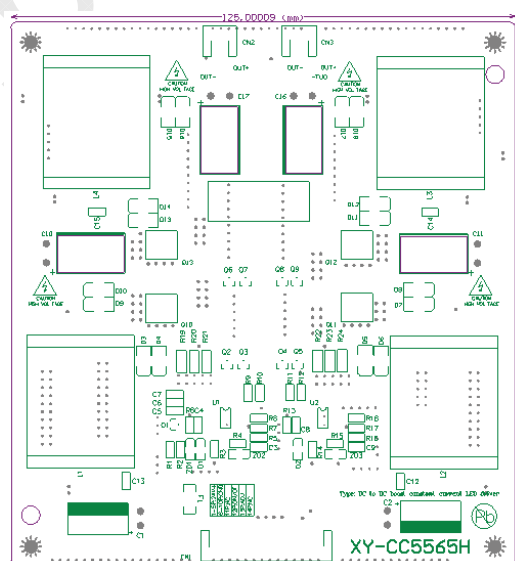
**(2) Mechanical Dimension**

The thickness of the board is 11MM (including components)

SPEC. NUMBER  
S8-65-8D-080

SPEC. TITLE  
DV550QUM-N10 Preliminary Product Specification P1

PAGE  
12 OF 40

DAS-RD-2019028-O

A4(210 X 297)

**BOE****PRODUCT GROUP**

REV

ISSUE DATE

Customer SPEC

P1

2019/08/22

**3.0 ELECTRICAL SPECIFICATIONS****3.6 LED Constant Current Source****(3) Environmental Condition**

&lt; Table 9. LED Constant Current Source Working Condition &gt;

Operating temperature	Storage temperature	Operating humidity	Storage humidity	Remark
-50°C -- 65°C	-20°C-- 70°C	10% -- 95%RH	10% -- 95%RH	Note1
-20°C -- 70°C		10% -- 95%RH		Note2

Note1: The DC to DC back-light inverter suggested working in the condition.

Note2: It can be work 300 thousand hours at least in the condition.

**(4) Electrical Characteristics**

&lt; Table 10. LED Constant Current Source Electrical Characteristics &gt;

NO	Item	Symbol	Test Conditions	Min	Type	Max	Unit
1	Input Voltage	Vin		22	24	26	V
2	Input Current	Iin			4.75	6	A
3	Input Power	Pin			104	142	W
4	Brightness Voltage	Vadj		0(Bright)	-	5(Dark)	V
5	Control Voltage		Enable Von=1.5~5.0V Disable Voff=0~0.5V				
6	Output Current (per group)	Iout	Vin=24.0V; Vout=57V; Ta=28°C		440	600	mA
7	Output Voltage	Vout	Vin=24.0V; Ta=28°C	60	118.8	185	V
8	Efficiency	η	Vin=24.0V; Vout=118V;		92.5		%
9	Output Total Group	Ggp			2		
10	Total Output Current	R			880	1200	mA
11	Output Power	Wout	Vin=24.0V; Vout=122.4V;		104	142	W

SPEC. NUMBER  
S8-65-8D-080SPEC. TITLE  
DV550QUM-N10 Preliminary Product Specification P1PAGE  
13 OF 40

DAS-RD-2019028-O

A4(210 X 297)

**BOE****PRODUCT GROUP**

REV

ISSUE DATE

Customer SPEC

P1

2019/08/22

**3.0 ELECTRICAL SPECIFICATIONS****3.6 LED Constant Current Source**

## (7) Sample Test Report

**SAMPLE TEST REPORT**

CUSTOMER:

MOOEL NO.

XY-CC5565H

**1.Input Charcteristics**

Parameter	Symbol /	Min	Typ	Max	Unit	Remark	Spec.Limit	Pass/Fail
Input Voltage	Vin	22	24	26	V	Input DC	22~26V	Pass
Input Current	Iin		4.75	6	A	Vadj=0V	4.75~6 A	Pass
Input Power	Pin		104	142	W		90~142W	Pass
Input Voltage On/offcontrol	Von/Off	2.5~5	2.5~5	2.5~5	V	On	2.5~5V	Pass
		0~0.5	0~0.5	0~0.5	V	Off	0~0.5V	Pass

**2.Output Characteristics**

Parameter	Symbol	Min	Typ	Max	Unit	Remark	Spec.Limit	Pass/Fail
Output Voltage	V+	60	118.8	185	V		60~185	Pass
Output Current	I+		880	1200	mA		880~1200	Pass

Low temperature test

0°C,(24VDC±10%) The sample OK

Please do not live in the assembly of the product, so as to avoid short circuit caused the product damage and other circuit board fault

Use this product to correspond to the required voltage, current parameter, otherwise cause the load capacity is insufficient or excessive flow, the impact of LED life

SPEC. NUMBER  
S8-65-8D-080

SPEC. TITLE

DV550QUM-N10 Preliminary Product Specification P1

PAGE

14 OF 40

DAS-RD-2019028-O

A4(210 X 297)

**BOE****PRODUCT GROUP**

REV

ISSUE DATE

Customer SPEC

P1

2019/08/22

**4.0 INTERFACE CONNECTION**

4.1 V by One CN (51Pin) Connector : F05035-51P-H(CHANGTONG) or Equivalent.

&lt; Table 11. Open Cell Input Connector Pin Configuration &gt;

Pin No	Symbol	Description	Pin No	Symbol	Description
1	VDD	Power Supply +12.0V	27	GND	Ground
2	VDD	Power Supply +12.0V	28	Rx0n	V-by-One HS Data Lane 0
3	VDD	Power Supply +12.0V	29	Rx0p	V-by-One HS Data Lane 0
4	VDD	Power Supply +12.0V	30	GND	Ground
5	VDD	Power Supply +12.0V	31	Rx1n	V-by-One HS Data Lane 1
6	VDD	Power Supply +12.0V	32	Rx1p	V-by-One HS Data Lane 1
7	VDD	Power Supply +12.0V	33	GND	Ground
8	VDD	Power Supply +12.0V	34	Rx2n	V-by-One HS Data Lane 2
9	NC	No Connection	35	Rx2p	V-by-One HS Data Lane 2
10	GND	Ground	36	GND	Ground
11	GND	Ground	37	Rx3n	V-by-One HS Data Lane 3
12	GND	Ground	38	Rx3p	V-by-One HS Data Lane 3
13	GND	Ground	39	GND	Ground
14	GND	Ground	40	Rx4n	V-by-One HS Data Lane 4
15	NC	No Connection	41	Rx4p	V-by-One HS Data Lane 4
16	NC	No Connection	42	GND	Ground
17	NC	No Connection	43	Rx5n	V-by-One HS Data Lane 5
18	SDA	SDA	44	Rx5p	V-by-One HS Data Lane 5
19	SCL	SCL	45	GND	Ground
20	NC	No Connection	46	Rx6n	V-by-One HS Data Lane 6
21	NC	No Connection	47	Rx6p	V-by-One HS Data Lane 6
22	SEL_SECTION	Low or NC: 1 section(default) High: 2 section	48	GND	Ground
23	NC	No Connection	49	Rx7n	V-by-One HS Data Lane 7
24	GND	Ground	50	Rx7p	V-by-One HS Data Lane 7
25	HTPDN	Hot plug detect	51	GND	Ground
26	LOCKN	Lock detect			

Note : NC(Not Connected) : These pins are only used for BOE internal operations.

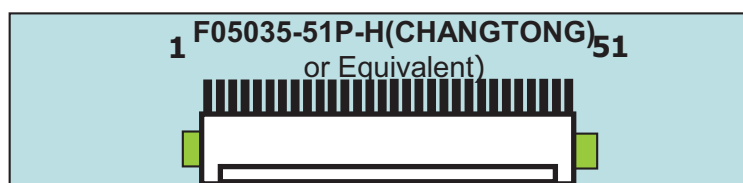
**Rear view of LCM****BIST Pattern**

PT1: Black (2 sec)	PT2: White (2 sec)	PT3: Red (2 sec)	PT4: Green (2 sec)	PT5: Blue (2 sec)

SPEC. NUMBER  
S8-65-8D-080SPEC. TITLE  
DV550QUM-N10 Preliminary Product Specification P1PAGE  
15 OF 40

DAS-RD-2019028-O

A4(210 X 297)

**BOE****PRODUCT GROUP**

REV

ISSUE DATE

Customer SPEC

P1

2019/08/22

**4.0 INTERFACE CONNECTION****4.2 V by one Misc. Setting for 1 Section.**

- a) System side has to put pull high resistor on LOCKN & HTPDN pins.  
b) V by one data mapping as follows.

&lt; Table 12. V by one setting &amp; data mapping table &gt;

1 Section								
Hactive = 3840								
	Port0		Port1		Port2		Port3	
	Lane0	Lane1	Lane2	Lane3	Lane4	Lane5	Lane6	Lane7
V Blanking	FSBS	FSBS	FSBS	FSBS	FSBS	FSBS	FSBS	FSBS
	FSBP	FSBP	FSBP	FSBP	FSBP	FSBP	FSBP	FSBP
	...	...	...	...	...	...	...	...
	FSBP	FSBP	FSBP	FSBP	FSBP	FSBP	FSBP	FSBP
	FSBE_SR	FSBE_SR	FSBE_SR	FSBE_SR	FSBE_SR	FSBE_SR	FSBE_SR	FSBE_SR
Line 1	Pixel 1	Pixel 2	Pixel 3	Pixel 4	Pixel 5	Pixel 6	Pixel 7	Pixel 8
	Pixel 9	Pixel 10	Pixel 11	Pixel 12	Pixel 13	Pixel 14	Pixel 15	Pixel 16
	...	...	...	...	...	...	...	...
	...	...	...	...	...	...	...	...
	Pixel 3833	Pixel 3834	Pixel 3835	Pixel 3836	Pixel 3837	Pixel 3838	Pixel 3839	Pixel 3840
H Blanking	FSBS	FSBS	FSBS	FSBS	FSBS	FSBS	FSBS	FSBS
	FSBP	FSBP	FSBP	FSBP	FSBP	FSBP	FSBP	FSBP
	...	...	...	...	...	...	...	...
	FSBP	FSBP	FSBP	FSBP	FSBP	FSBP	FSBP	FSBP
	FSBE	FSBE	FSBE	FSBE	FSBE	FSBE	FSBE	FSBE
Line 2	Pixel 1	Pixel 2	Pixel 3	Pixel 4	Pixel 5	Pixel 6	Pixel 7	Pixel 8
	Pixel 9	Pixel 10	Pixel 11	Pixel 12	Pixel 13	Pixel 14	Pixel 15	Pixel 16
	...	...	...	...	...	...	...	...
	...	...	...	...	...	...	...	...
	Pixel 3833	Pixel 3834	Pixel 3835	Pixel 3836	Pixel 3837	Pixel 3838	Pixel 3839	Pixel 3840

SPEC. NUMBER  
S8-65-8D-080

SPEC. TITLE  
DV550QUM-N10 Preliminary Product Specification P1

PAGE  
16 OF 40

DAS-RD-2019028-O

A4(210 X 297)



**BOE****PRODUCT GROUP**

REV

ISSUE DATE

Customer SPEC

P1

2019/08/22

**4.0 INTERFACE CONNECTION****4.3 V by one Misc. Setting for 2 Section.**

- a) System side has to put pull high resistor on LOCKN & HTPDN pins.  
b) V by one data mapping as follows.

&lt; Table 13. V by one setting &amp; data mapping table &gt;

2 Section								
Hactive = 3840								
	Port0		Port1		Port2		Port3	
	Lane0	Lane1	Lane2	Lane3	Lane4	Lane5	Lane6	Lane7
V Blanking	FSBS	FSBS	FSBS	FSBS	FSBS	FSBS	FSBS	FSBS
	FSBP	FSBP	FSBP	FSBP	FSBP	FSBP	FSBP	FSBP
	...	...	...	...	...	...	...	...
	FSBP	FSBP	FSBP	FSBP	FSBP	FSBP	FSBP	FSBP
	FSBE_SR	FSBE_SR	FSBE_SR	FSBE_SR	FSBE_SR	FSBE_SR	FSBE_SR	FSBE_SR
Line 1	Pixel 1	Pixel 2	Pixel 3	Pixel 4	Pixel 1921	Pixel 1922	Pixel 1923	Pixel 1924
	Pixel 5	Pixel 6	Pixel 7	Pixel 8	Pixel 1925	Pixel 1926	Pixel 1927	Pixel 1928
	...	...	...	...	...	...	...	...
	...	...	...	...	...	...	...	...
	Pixel 1917	Pixel 1918	Pixel 1919	Pixel 1920	Pixel 3837	Pixel 3838	Pixel 3839	Pixel 3840
H Blanking	FSBS	FSBS	FSBS	FSBS	FSBS	FSBS	FSBS	FSBS
	FSBP	FSBP	FSBP	FSBP	FSBP	FSBP	FSBP	FSBP
	...	...	...	...	...	...	...	...
	FSBP	FSBP	FSBP	FSBP	FSBP	FSBP	FSBP	FSBP
	FSBE	FSBE	FSBE	FSBE	FSBE	FSBE	FSBE	FSBE
Line 2	Pixel 1	Pixel 2	Pixel 3	Pixel 4	Pixel 1921	Pixel 1922	Pixel 1923	Pixel 1924
	Pixel 5	Pixel 6	Pixel 7	Pixel 8	Pixel 1925	Pixel 1926	Pixel 1927	Pixel 1928
	...	...	...	...	...	...	...	...
	...	...	...	...	...	...	...	...
	Pixel 1917	Pixel 1918	Pixel 1919	Pixel 1920	Pixel 3837	Pixel 3838	Pixel 3839	Pixel 3840

SPEC. NUMBER  
S8-65-8D-080

SPEC. TITLE  
DV550QUM-N10 Preliminary Product Specification P1

PAGE  
17 OF 40

DAS-RD-2019028-O

A4(210 X 297)

<b>BOE</b>	<b>PRODUCT GROUP</b>	REV	ISSUE DATE
	Customer SPEC	P1	2019/08/22

### 4.0 INTERFACE CONNECTION

#### 4.4 TCON Board Input CNT & FFC Drawing

##### -51pin Connector Drawing-F05035-51P-H (Changtong)

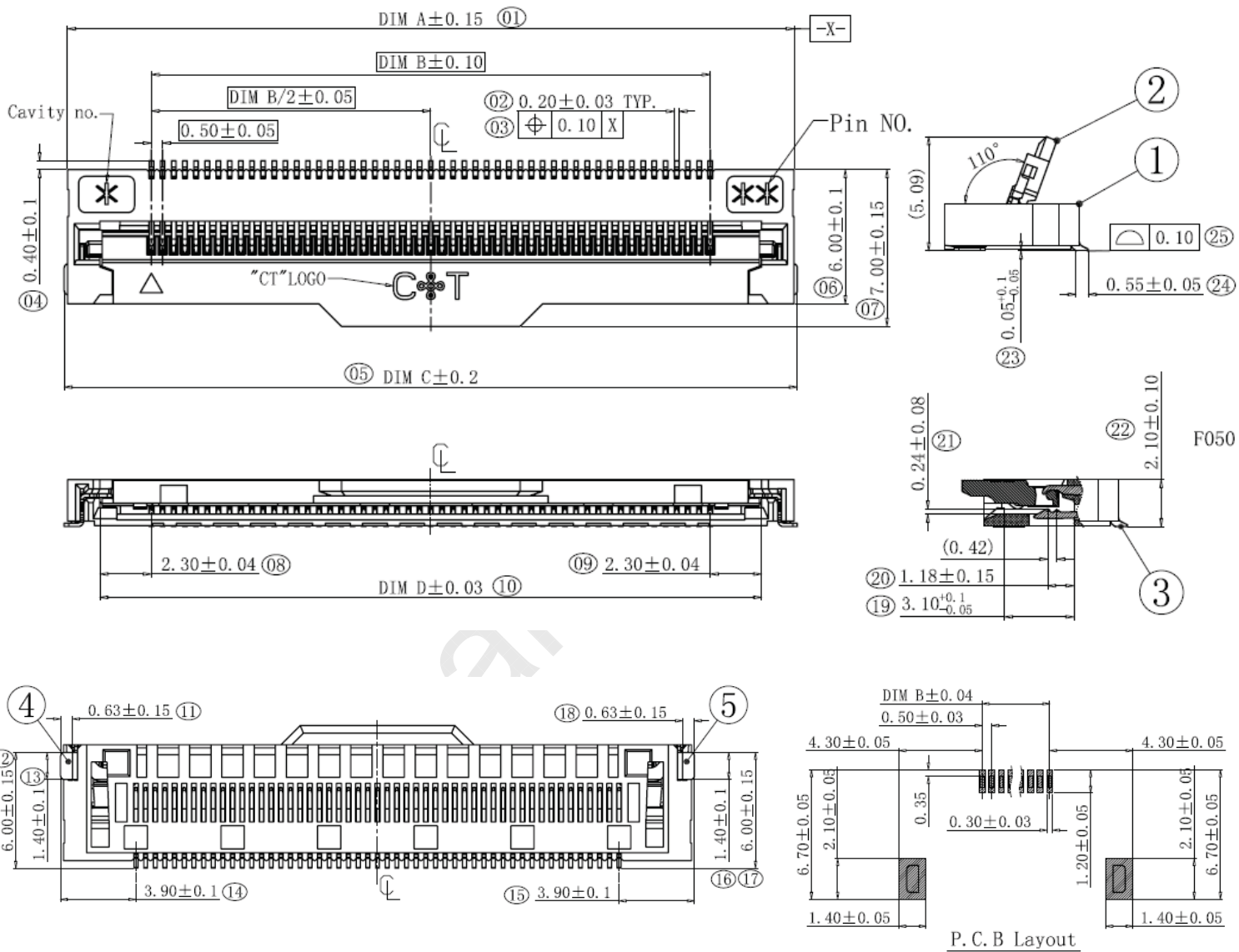

PIN NO.	DIM A	DIM B	DIM C	DIM D
30	22.00	14.50	22.30	19.10
41	27.50	20.00	27.80	24.60
51	32.50	25.00	32.80	29.60

**BOE**

PRODUCT GROUP

REV

ISSUE DATE

Customer SPEC

P1

2019/08/22

-51pin Connector Drawing-PM.FPC.LVS0505101(UJC)

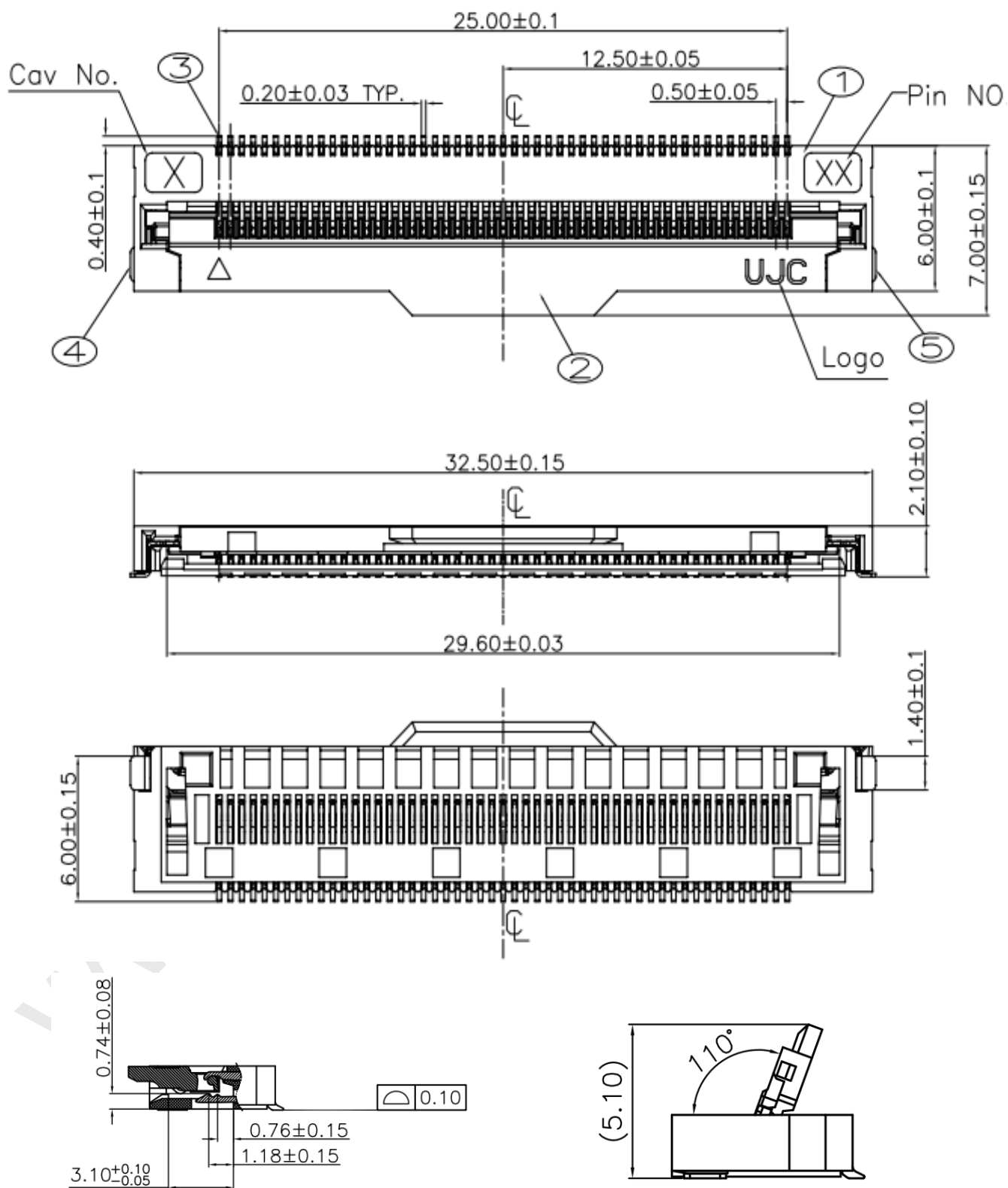

SPEC. NUMBER  
S8-65-8D-080

SPEC. TITLE  
DV550QUM-N10 Preliminary Product Specification P1

PAGE  
19 OF 40

	PRODUCT GROUP	REV	ISSUE DATE
	Customer SPEC	P1	2019/08/22

## 4.0 INTERFACE CONNECTION

### 4.4 TCON Board Input CNT & FFC Drawing

#### -FFC Drawing

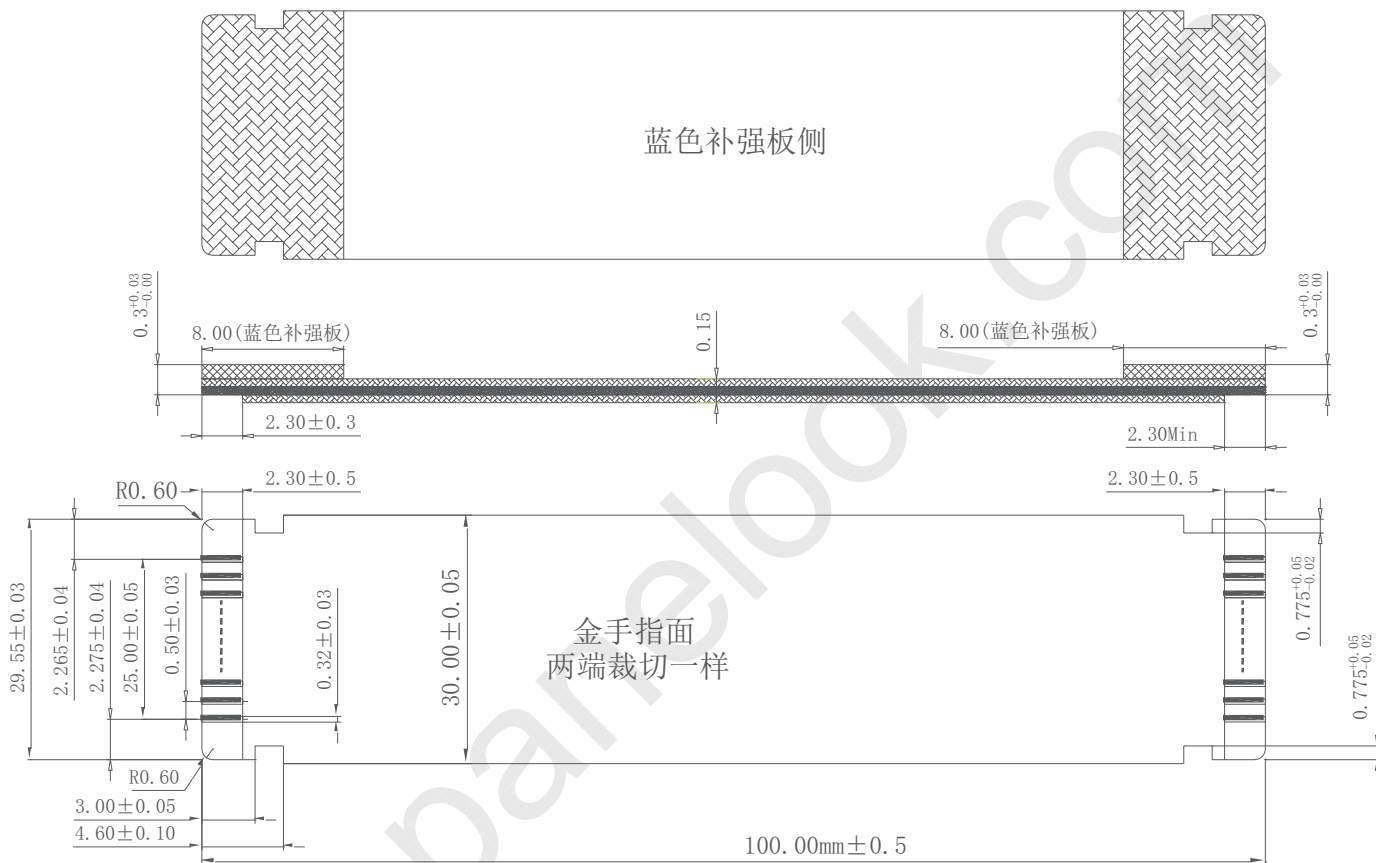

Note: It is BOE FFC drawing. Please refer to only one side for T-con Board.

SPEC. NUMBER S8-65-8D-080	SPEC. TITLE DV550QUM-N10 Preliminary Product Specification P1	PAGE 20 OF 40
------------------------------	--	------------------

<h1>BOE</h1>	<h2>PRODUCT GROUP</h2>	REV	ISSUE DATE
	Customer SPEC	P1	2019/08/22

### 4.0 INTERFACE CONNECTION

#### 4.5 TCON Board Output CNT & FFC Drawing

##### -60pin Connector Drawing-PM.FPC.LVS0506001(UJC)

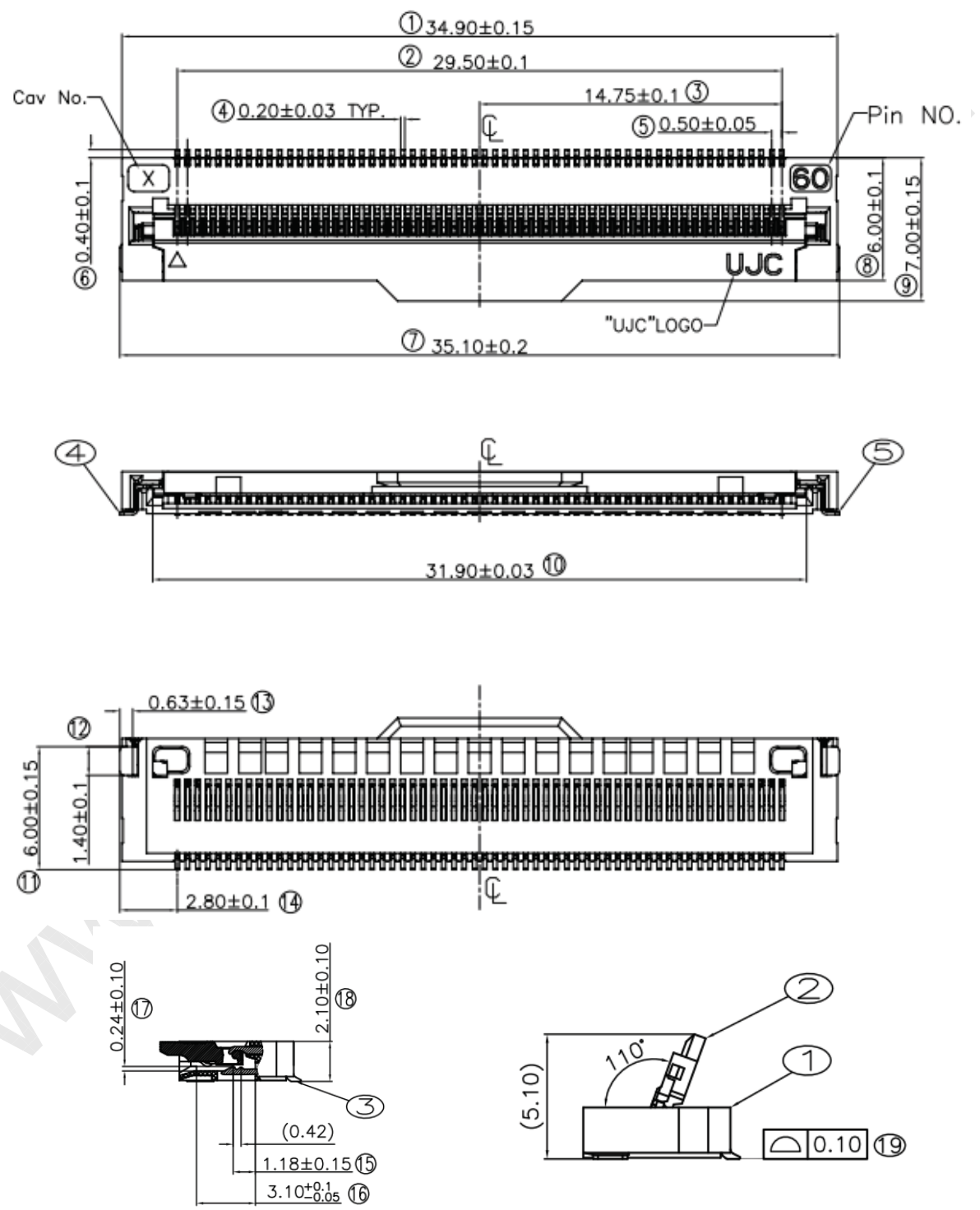

Note: TCON Board output CNT = XPCBA Input CNT.

SPEC. NUMBER S8-65-8D-080	SPEC. TITLE DV550QUM-N10 Preliminary Product Specification P1	PAGE 21 OF 40
------------------------------	--	------------------

DAS-RD-2019028-O

A4(210 X 297)

**BOE**

**PRODUCT GROUP**

REV

ISSUE DATE

Customer SPEC

P1

2019/08/22

-60pin Connector Drawing-F05039-60P-H(Changtong)

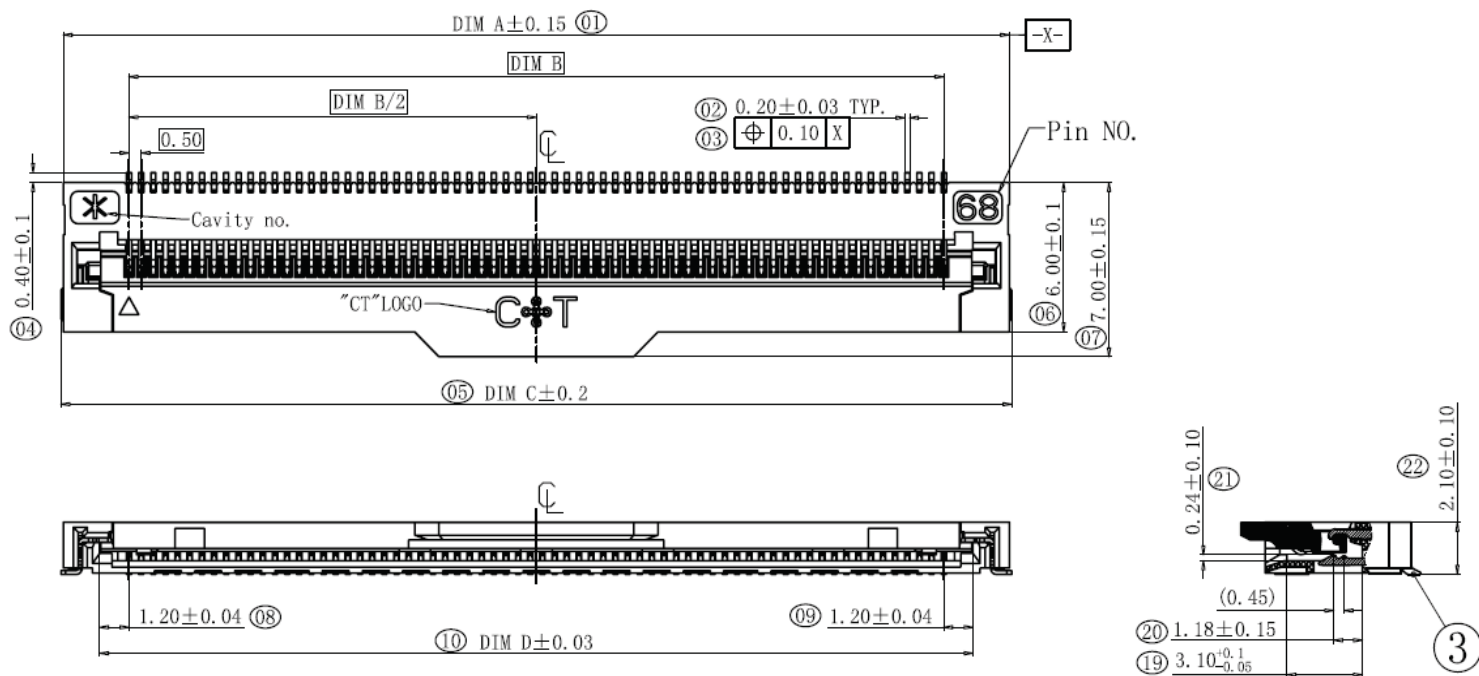

PIN NO.	DIM A	DIM B	DIM C	DIM D
60	34.90	29.50	35.10	31.90

Note: TCON Board output CNT = XPCBA Input CNT.

-FFC Drawing

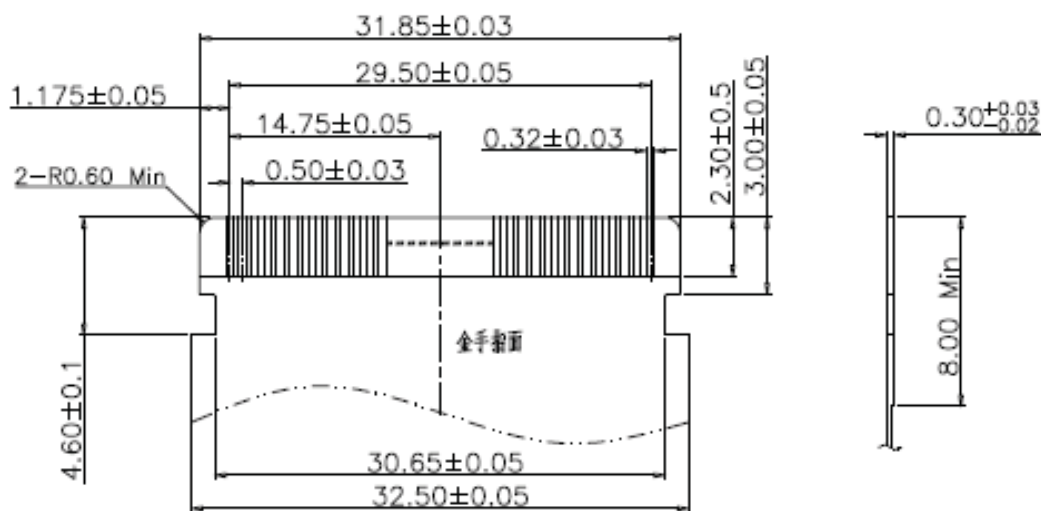

Notes: This FFC drawing is supplied by the connector vendor.

SPEC. NUMBER  
S8-65-8D-080

SPEC. TITLE  
DV550QUM-N10 Preliminary Product Specification P1

PAGE  
22 OF 40

DAS-RD-2019028-O

A4(210 X 297)

**BOE****PRODUCT GROUP**

REV

ISSUE DATE

Customer SPEC

P1

2019/08/22

**5.0 SIGNAL TIMING WAVEFORMS OF INTERFACE SIGNAL****5.1 Input data specification**

&lt;Table 14. Vx1 Byte length and Color mapping&gt;

Byte	Packer input	Color data mapping	
		30 bpp RGB	24 bpp RGB
0	Bit-0	R2	R0
	Bit-1	R3	R1
	Bit-2	R4	R2
	Bit-3	R5	R3
	Bit-4	R6	R4
	Bit-5	R7	R5
	Bit-6	R8	R6
	Bit-7	R9	R7
1	Bit-8	G2	G0
	Bit-9	G3	G1
	Bit-10	G4	G2
	Bit-11	G5	G3
	Bit-12	G6	G4
	Bit-13	G7	G5
	Bit-14	G8	G6
	Bit-15	G9	G7
2	Bit-16	B2	B0
	Bit-17	B3	B1
	Bit-18	B4	B2
	Bit-19	B5	B3
	Bit-20	B6	B4
	Bit-21	B7	B5
	Bit-22	B8	B6
	Bit-23	B9	B7
3	Bit-24	-	-
	Bit-25	-	-
	Bit-26	B0	-
	Bit-27	B1	-
	Bit-28	G0	-
	Bit-29	G1	-
	Bit-30	R0	-
	Bit-31	R1	-

SPEC. NUMBER  
S8-65-8D-080

SPEC. TITLE

DV550QUM-N10 Preliminary Product Specification P1

PAGE

23 OF 40

DAS-RD-2019028-O

A4(210 X 297)

**BOE****PRODUCT GROUP**

REV

ISSUE DATE

Customer SPEC

P1

2019/08/22

**5.0 SIGNAL TIMING WAVEFORMS OF INTERFACE SIGNAL****5.2 Vx1 Input Signal Timing**

&lt; Table 15. Signal Timing Waveforms Table &gt;

Parameter	Symbol	Condition	Min	Typ	Max	Unit
Unit Interval(VBO Operation Bit Rate)	tRBIT	3-byte	380	tTCIP/30	1667	PS
		4-byte	285	tTCIP/40	1250	PS
		5-byte	266	tTCIP/50	1000	PS
Eye Width at Package Pin	tREYE	-	-	0.5	-	UI
Eye Width Position A at Package Pin	tA	-	-	0.25	-	UI
Eye Width Position B at Package Pin	tB	-	-	0.3	-	UI
Eye Width Position Cat Package Pin	tC	-	-	0.7	-	UI
Eye Width Position D at Package Pin	tD	-	-	0.75	-	UI
Eye Width Position E at Package Pin	tE	-	-	0.7	-	UI
Eye Width Position F at Package Pin	tF	-	-	0.3	-	UI
Intra – pair Skew	TTOSK_intra	-	-0.3	-	0.3	UI
Inter – pair Skew	TTOSK_inter	-	-5	-	5	UI
SSCG	-	30KHz modulation	-0.5	-	0.5	%

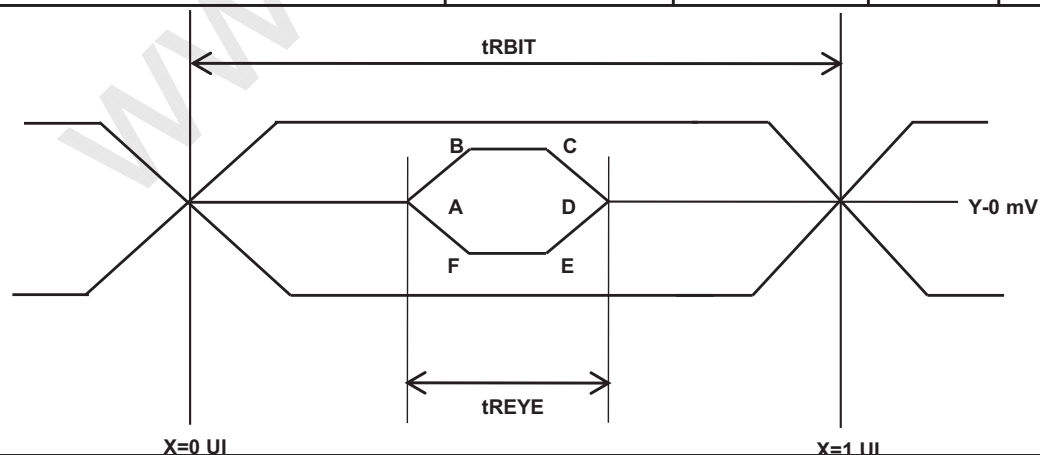

	Y[mV]
A	0
B	50
C	50
D	0
E	-50
F	-50

SPEC. NUMBER  
S8-65-8D-080SPEC. TITLE  
DV550QUM-N10 Preliminary Product Specification P1PAGE  
24 OF 40

DAS-RD-2019028-O

A4(210 X 297)



**BOE****PRODUCT GROUP**

REV

ISSUE DATE

Customer SPEC

P1

2019/08/22

**6.0 SIGNAL TIMING SPECIFICATION****6.1 Timing Parameters(DE only mode)**

&lt; Table 16. Timing Table &gt;

Item	Symbols	Min	Typ	Max	Unit	
Frequency	1/Tc	69	74.25	77	MHz	
Vertical	Frame Rate	F	57	60	62	Hz
	Total	T <sub>V</sub>	2180	2250	2450	T <sub>H</sub>
	Display	T <sub>VD</sub>	2160			T <sub>H</sub>
	Blank	T <sub>VB</sub>	20	90	290	T <sub>H</sub>
Horizontal	Total	T <sub>H</sub>	530	550	570	T <sub>CLK</sub>
	Display	T <sub>HD</sub>	-	480	-	T <sub>CLK</sub>
	Blank	T <sub>HB</sub>	50	70	90	T <sub>CLK</sub>

Item	Symbols	Min	Typ	Max	Unit	
Frequency	1/Tc	69	74.25	77	MHz	
Vertical	Frame Rate	F	47	50	51	Hz
	Total	T <sub>V</sub>	2180	2700	2715	T <sub>H</sub>
	Display	T <sub>VD</sub>	2160			T <sub>H</sub>
	Blank	T <sub>VB</sub>	20	540	555	T <sub>H</sub>
Horizontal	Total	T <sub>H</sub>	530	550	570	T <sub>CLK</sub>
	Display	T <sub>HD</sub>	-	480	-	T <sub>CLK</sub>
	Blank	T <sub>HB</sub>	50	70	90	T <sub>CLK</sub>

Notes: This product is DE only mode. The input of Hsync & Vsync signal does not have an effect on normal operation.

SPEC. NUMBER  
S8-65-8D-080

SPEC. TITLE  
DV550QUM-N10 Preliminary Product Specification P1

PAGE  
25 OF 40

DAS-RD-2019028-O

A4(210 X 297)

<b>BOE</b>	<b>PRODUCT GROUP</b>	<b>REV</b>	<b>ISSUE DATE</b>
	Customer SPEC	P1	2019/08/22

**6.0 SIGNAL TIMING SPECIFICATION**

**6.2 Input Signals, Basic Display Colors and Gray Scale of Colors**

< Table 17. Input Signal and Display Color Table >

Color		Input Color Data																																						
		MSB RED LSB										MSB GREEN LSB										MSB BLUE LSB																		
		R9	R8	R7	R6	R5	R4	R3	R2	R1	R0	G9	G8	G7	G6	G5	G4	G3	G2	G1	G0	B9	B8	B7	B6	B5	B4	B3	B2	B1	B0									
Basic Color	Black	0	0	0	0	0	0	0	0	0	0	0	0	0	0	0	0	0	0	0	0	0	0	0	0	0	0	0	0	0	0	0	0	0	0	0	0	0	0	0
	Red(1023)	1	1	1	1	1	1	1	1	1	0	0	0	0	0	0	0	0	0	0	0	0	0	0	0	0	0	0	0	0	0	0	0	0	0	0	0	0	0	0
	Green(1023)	0	0	0	0	0	0	0	0	0	1	1	1	1	1	1	1	1	1	1	0	0	0	0	0	0	0	0	0	0	0	0	0	0	0	0	0	0	0	0
	Blue(1023)	0	0	0	0	0	0	0	0	0	0	0	0	0	0	0	0	0	0	0	1	1	1	1	1	1	1	1	1	1	0	0	0	0	0	0	0	0	0	0
	Cyan	0	0	0	0	0	0	0	0	0	1	1	1	1	1	1	1	1	1	1	1	1	1	1	1	1	1	1	1	1	0	0	0	0	0	0	0	0	0	0
	Magenta	1	1	1	1	1	1	1	1	1	0	0	0	0	0	0	0	0	0	0	0	0	0	0	0	0	0	0	0	0	1	1	1	1	1	1	1	1	1	1
	Yellow	1	1	1	1	1	1	1	1	1	1	1	1	1	1	1	1	1	1	1	0	0	0	0	0	0	0	0	0	0	0	0	0	0	0	0	0	0	0	0
	White	1	1	1	1	1	1	1	1	1	1	1	1	1	1	1	1	1	1	1	1	1	1	1	1	1	1	1	1	1	1	1	1	1	1	1	1	1	1	1
R	RED(000)	0	0	0	0	0	0	0	0	0	0	0	0	0	0	0	0	0	0	0	0	0	0	0	0	0	0	0	0	0	0	0	0	0	0	0	0	0	0	
	RED(001)	0	0	0	0	0	0	0	0	1	0	0	0	0	0	0	0	0	0	0	0	0	0	0	0	0	0	0	0	0	0	0	0	0	0	0	0	0	0	
	----																																							
	RED(1022)	1	1	1	1	1	1	1	1	0	0	0	0	0	0	0	0	0	0	0	0	0	0	0	0	0	0	0	0	0	0	0	0	0	0	0	0	0	0	
	RED(1023)	1	1	1	1	1	1	1	1	1	0	0	0	0	0	0	0	0	0	0	0	0	0	0	0	0	0	0	0	0	0	0	0	0	0	0	0	0	0	
G	Green (000)	0	0	0	0	0	0	0	0	0	0	0	0	0	0	0	0	0	0	0	0	0	0	0	0	0	0	0	0	0	0	0	0	0	0	0	0	0	0	
	Green (000)	0	0	0	0	0	0	0	0	0	0	0	0	0	0	0	0	0	1	0	0	0	0	0	0	0	0	0	0	0	0	0	0	0	0	0	0	0	0	
	----																																							
	Green (1022)	0	0	0	0	0	0	0	0	0	1	1	1	1	1	1	1	1	1	0	0	0	0	0	0	0	0	0	0	0	0	0	0	0	0	0	0	0	0	
	Green (1023)	0	0	0	0	0	0	0	0	0	1	1	1	1	1	1	1	1	1	0	0	0	0	0	0	0	0	0	0	0	0	0	0	0	0	0	0	0	0	
B	Blue(000)	0	0	0	0	0	0	0	0	0	0	0	0	0	0	0	0	0	0	0	0	0	0	0	0	0	0	0	0	0	0	0	0	0	0	0	0	0	0	
	Blue(000)	0	0	0	0	0	0	0	0	0	0	0	0	0	0	0	0	0	0	0	0	0	0	0	0	0	0	0	0	0	0	0	0	0	0	0	0	0	1	
	----																																							
	Blue(1022)	0	0	0	0	0	0	0	0	0	0	0	0	0	0	0	0	0	0	1	1	1	1	1	1	1	1	1	1	0	0	0	0	0	0	0	0	0	0	
	Blue(1023)	0	0	0	0	0	0	0	0	0	0	0	0	0	0	0	0	0	0	1	1	1	1	1	1	1	1	1	1	0	0	0	0	0	0	0	0	0	0	

SPEC. NUMBER S8-65-8D-080	SPEC. TITLE DV550QUM-N10 Preliminary Product Specification P1	PAGE 26 OF 40
------------------------------	--	------------------

DAS-RD-2019028-O

A4(210 X 297)

**BOE****PRODUCT GROUP**

REV

ISSUE DATE

Customer SPEC

P1

2019/08/22

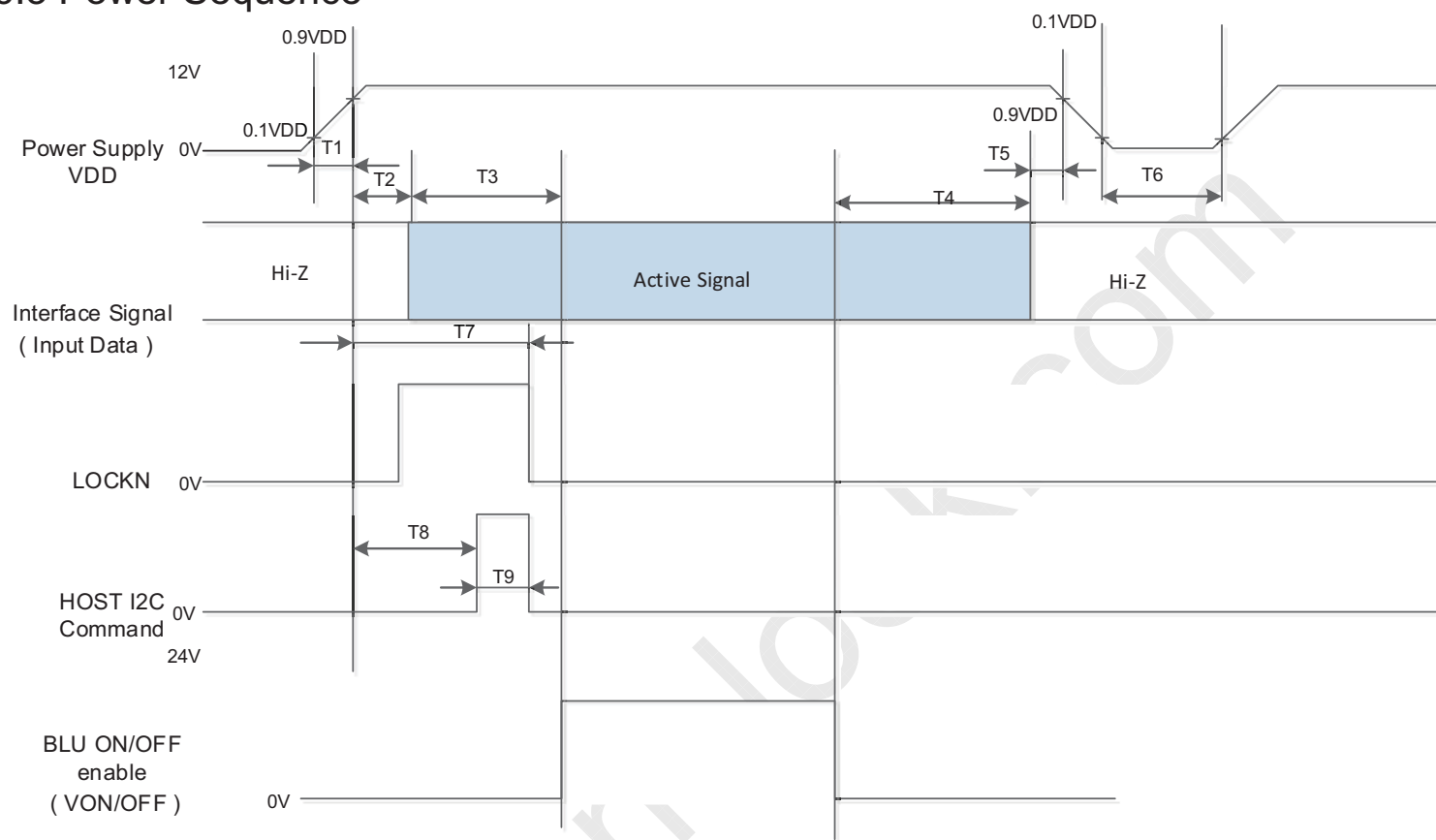
**6.0 SIGNAL TIMING SPECIFICATION****6.3 Power Sequence**

&lt; Table 18. Sequence Table &gt;

Parameter	Values			Units
	Min	Typ	Max	
T1	0.5	-	10	ms
T2	0	-	-	ms
T3	200	-	-	ms
T4	100	-	-	ms
T5	0	-	-	ms
T6	1	-	-	s
T7	-	-	200	ms
T8	1200	-	-	ms
T9	Depends on I2C command			ms

Notes: 1. Even though T1 is over the specified value, there is no problem if I2T spec of fuse is satisfied.

2. Back Light must be turn on after power for logic and interface signal are valid.

SPEC. NUMBER  
S8-65-8D-080SPEC. TITLE  
DV550QUM-N10 Preliminary Product Specification P1PAGE  
27 OF 40

DAS-RD-2019028-O

A4(210 X 297)

**BOE****PRODUCT GROUP**

REV

ISSUE DATE

Customer SPEC

P1

2019/08/22

**7.0 OPTICAL SPECIFICATION**

The test of optical specifications shall be measured in a dark room (ambient luminance $\leq$ 1 lux and temperature $=25\pm 2^{\circ}\text{C}$ ) with the equipment of Luminance meter system (Goniometer system and PR730) and test unit shall be located at an approximate distance 180cm from the LCD surface at a viewing angle of  $\theta$  and  $\Phi$  equal to  $0^{\circ}$ . We refer to  $\theta_{\Phi=0}$  ( $=\theta_3$ ) as the 3 o'clock direction (the "right"),  $\theta_{\Phi=90}$  ( $=\theta_{12}$ ) as the 12 o'clock direction ("upward"),  $\theta_{\Phi=180}$  ( $=\theta_9$ ) as the 9 o'clock direction ("left") and  $\theta_{\Phi=270}$  ( $=\theta_6$ ) as the 6 o'clock direction ("bottom"). While scanning  $\theta$  and/or  $\Phi$ , the center of the measuring spot on the Display surface shall stay fixed. The measurement shall be executed after 30 minutes warm-up period. VDD shall be 12.0V  $\pm$ 10% at  $25^{\circ}\text{C}$ . Optimum viewing angle direction is 6 'clock.

&lt; Table 19. Optical Table &gt;

[VDD = 12.0V, Frame rate = 60Hz, Ta =  $25\pm 2^{\circ}\text{C}$ ]

Parameter		Symbol	Condition	Min	Typ	Max	Unit	Remark
Viewing Angle	Horizontal	$\theta_3$	CR > 10	-	89	-	Deg.	Note 1
		$\theta_9$		-	89	-	Deg.	
	Vertical	$\theta_{12}$		-	89	-	Deg.	
		$\theta_6$		-	89	-	Deg.	
Contrast ratio		CR		1000:1	1200:1	-	-	Note 2
Reproduction of color	White	$W_x$	$\theta = 0^{\circ}$ (Center) Normal Viewing Angle	TYP. - 0.03	0.280	TYP. + 0.03	-	Note 3
		$W_y$			0.290		-	
	Red	$R_x$			0.641		-	
		$R_y$			0.340		-	
	Green	$G_x$			0.302		-	
		$G_y$			0.619		-	
	Blue	$B_x$			0.154		-	
		$B_y$			0.052		-	
Response Time	G to G	$T_g$		-	8	10	ms	Note 4
Gamma Scale				2.0	2.2	2.4	-	$2.2\pm 0.3$ (50~128 Gray)
Cell Transmittance				4.8	5.4	-	%	Note 5
Surface Luminance, white		$L_{WH}$		720	800	-	$\text{cd}/\text{m}^2$	Note 6
Luminance Variation		$\delta_{\text{WHITE}}$	gP	70	75	-	%	Note 7

SPEC. NUMBER  
S8-65-8D-080SPEC. TITLE  
DV550QUM-N10 Preliminary Product Specification P1PAGE  
28 OF 40

DAS-RD-2019028-O

A4(210 X 297)



<b>BOE</b>	<b>PRODUCT GROUP</b>	REV	ISSUE DATE
	Customer SPEC	P1	2019/08/22

Note :

1. Viewing angle is the angle at which the contrast ratio is greater than 10. The viewing are determined for the horizontal or 3, 9 o'clock direction and the vertical or 6, 12 o'clock direction with respect to the optical axis which is normal to the LCD surface.
2. Contrast measurements shall be made at viewing angle of  $\theta = 0^\circ$  and at the center of the LCD surface. Luminance shall be measured with all pixels in the view field set first to white, then to the dark (black) state. (See Figure 1 shown in Appendix) Luminance Contrast Ratio (CR) is defined mathematically.

$$CR = \frac{\text{Luminance when displaying a white raster}}{\text{Luminance when displaying a black raster}}$$

3. The color chromaticity coordinates specified in Table 187 shall be calculated from the spectral data measured with all pixels first in red, green, blue. Measurements shall be made at the center of the panel. The BLU is used by BOE.
4. Response time Tg is the average time required for display transition by switching the input signal as below table and is based on Frame rate fV =60Hz to optimize. Each time in below table is defined as Figure 2 and shall be measured by switching the input signal for "any level of gray(bright)" and "any level of gray(dark)"

Measured Response Time	Target																
	0	15	31	47	63	79	95	111	127	143	159	175	191	207	223	239	255
Start	0																
	15																
	31																
	47																
	63																
	79																
	95																
	111																
	127																
	143																
	159																
	175																
	191																
	207																
	223																
	239																
	255																

5. Definition of Transmittance (T%) :

Module is with white(L255) signal input

$$\text{Transmittance} = \frac{\text{Luminance of LCD Module}}{\text{Luminance of BLU}} \times 100 \%$$

SPEC. NUMBER S8-65-8D-080	SPEC. TITLE DV550QUM-N10 Preliminary Product Specification P1	PAGE 29 OF 40
------------------------------	--	------------------

**BOE****PRODUCT GROUP**

REV

ISSUE DATE

Customer SPEC

P1

2019/08/22

Note :

6. Surface luminance are determined after the unit has been 'ON' and 1 Hour after lighting the backlight in a dark environment at  $25 \pm 2^\circ\text{C}$ . Surface luminance is the luminance value at center 1-point across the LCD surface 50cm from the surface with all pixels displaying white.
7. The variation in surface luminance,  $\delta$  WHITE is define as:

$$\delta \text{ WHITE}(9P) = \text{Minimum}(L_{\text{on}1}, L_{\text{on}2}, L_{\text{on}3}, L_{\text{on}4}, L_{\text{on}9}) / \text{Maximum}(L_{\text{on}1}, L_{\text{on}2}, L_{\text{on}3}, L_{\text{on}4}, L_{\text{on}9})$$

Where  $L_{\text{on}1}$  to  $L_{\text{on}9}$  are the luminance with all pixels displaying while at 9 locations.

For more information, see the Figure 3(located in Appendix).

SPEC. NUMBER  
S8-65-8D-080

SPEC. TITLE  
DV550QUM-N10 Preliminary Product Specification P1

PAGE  
30 OF 40

DAS-RD-2019028-O

A4(210 X 297)

**BOE****PRODUCT GROUP**

REV

ISSUE DATE

Customer SPEC

P1

2019/08/22

## 8.0 MECHANICAL CHARACTERISTICS

### 8.1 Dimensional Requirements

Figure 4(located in Appendix) shows mechanical outlines for the model DV550QUM-N10. Other parameters are shown in Table 20.

< Table 20. Dimensional Parameters >

Parameter	Specification	Unit
Active area	1209.6 (H) × 680.4(V)	mm
Pixel pitch	315 (H) × 315 (V)	μm
Number of pixels	3840(H) × 2160(V) (TFT pixel) 3840(H) × 2160(V) (1 CF pixel= R + G + B dots)	pixels
MDL Dimensional outline	1232.4(H) x 703.2(V) x 17(B)	mm
Weight	15	kg

### 8.2 Mounting

See Figure 5. (Shown in Appendix)

### 8.3 Anti-Glare and Polarizer Hardness

The surface of the LCD has an low haze coating to reduce scratching. Front Polarizer hardness is at less 3H.

SPEC. NUMBER  
S8-65-8D-080

SPEC. TITLE  
DV550QUM-N10 Preliminary Product Specification P1

PAGE  
31 OF 40

DAS-RD-2019028-O

A4(210 X 297)

**BOE****PRODUCT GROUP**

REV

ISSUE DATE

Customer SPEC

P1

2019/08/22

**9.0 RELIABILITY TEST**

The Reliability test items and its conditions are shown in below.

< Table 21. Reliability Test Parameters >

No	Test Items	Conditions
1	High temperature storage test	Ta = 60 °C, 240 hrs
2	Low temperature storage test	Ta = -20 °C, 240 hrs
3	High temperature & high humidity operation test	Ta = 50 °C, 80%RH, 240hrs
4	High temperature operation test	Ta = 50 °C, 240hrs
5	Low temperature operation test	Ta = -5 °C, 240hrs
6	Thermal shock	Ta = -20 °C ↔ 60 °C (0.5 hr), 100 cycle
7	Packing VIB	1.20Grms, 1-200Hz, Random +Z 1hr
8	Electro-static discharge test	Air : ± 15kV , 150pF/330Ω , 100Point , 1time/Point Contact : ± 8kV , 150pF/330Ω , 100Point , 1time/Point Non operation Contact: ± 4KV~ ± 6KV, 150pF/330Ω, 100Point, Input connector Pin, 3 times/pin with no function loss

SPEC. NUMBER  
S8-65-8D-080

SPEC. TITLE  
DV550QUM-N10 Preliminary Product Specification P1

PAGE  
32 OF 40

DAS-RD-2019028-O

A4(210 X 297)



**BOE****PRODUCT GROUP**

REV

ISSUE DATE

Customer SPEC

P1

2019/08/22

**10.0 HANDLING & CAUTIONS****(1) Cautions when taking out the Panel**

- Pick the pouch only, when taking out panel from a shipping package.

**(2) Cautions for handling the panel**

- As the electrostatic discharges may break the LCD panel, handle the LCD panel with care. Peel a protection sheet off from the LCD panel surface as slowly as possible.
- As the LCD panel and back - light element are made from fragile glass material, impulse and pressure to the LCD panel should be avoided.
- As the surface of the polarizer is very soft and easily scratched, use a soft dry cloth without chemicals for cleaning.
- Do not pull the interface connector in or out while the LCD panel is operating.
- Put the panel display side down on a flat horizontal plane.
- Handle connectors and cables with care.

**(3) Cautions for the operation**

- When the panel is operating, do not lose CLK, ENAB signals. If any one of these signals is lost, the LCD panel would be damaged.
- Obey the supply voltage sequence. If wrong sequence is applied, the panel would be damaged.

**(4) Cautions for the atmosphere**

- Dew drop atmosphere should be avoided.
- Do not store and/or operate the LCD panel in a high temperature and/or humidity atmosphere. Storage in an electro-conductive polymer packing pouch and under relatively low temperature atmosphere is recommended.

**(5) Cautions for the panel characteristics**

- Do not apply fixed pattern data signal to the LCD panel at product aging.
- Applying fixed pattern for a long time may cause image sticking.

**(6) Other cautions**

- Do not disassemble and/or re-assemble LCD panel.
- Do not re-adjust variable resistor or switch etc.
- When returning the panel for repair or etc., Please pack the panel not to be broken. We recommend to use the original shipping packages.

SPEC. NUMBER  
S8-65-8D-080SPEC. TITLE  
DV550QUM-N10 Preliminary Product Specification P1PAGE  
33 OF 40

<b>BOE</b>	<b>PRODUCT GROUP</b>	REV	ISSUE DATE
	Customer SPEC	P1	2019/08/22

**11.0 PRODUCT SERIAL NUMBER**

- Label Size : 80 mm (L) × 25 mm (W)
- Label Picture:

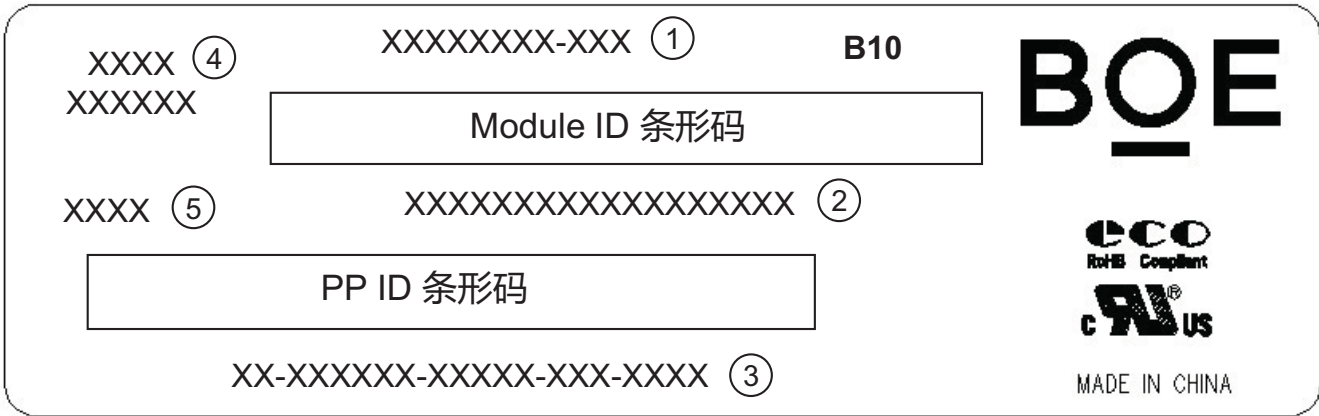

**打印内容，说明如下:**

- ① FG-CODE
- ② Module ID，最后一位为Revision Code（扫描不显示），前17位编码规则如下
- ③ PPID（客户端ID）
- ④ D/PN码，规格待确定
- ⑤ 生产年份+生产周别（中间无空格）

**Module ID编码原则**

Digit	1	2	3	4	5	6	7	8	9	10	11	12	13	14	15	16	17
Code	S	L	S	A	1	0	8	5	9	4	2	0	0	0	1	D	B
Description	Product Code/GBN → FG-CODE 一一对应		Grade	line	Year	Month	Model Extension Code (Last 4 Digits of FG-CODE)				Serial No. Hex-Decimal 000000-FFFFFF						

SPEC. NUMBER S8-65-8D-080	SPEC. TITLE DV550QUM-N10 Preliminary Product Specification P1	PAGE 34 OF 40
------------------------------	--	------------------

**BOE****PRODUCT GROUP**

REV

ISSUE DATE

Customer SPEC

P1

2019/08/22

## 12.0 PACKING

BOE provides the standard shipping container for customers, unless customer specifies their packing information. The standard packing method and Barcode information are shown in below.

### 12.1 Packing Specifications

- 8 LCD TV modules/ 1 Box
- Box dimensions: 1370(L) x565(W) x787(H)mm
- Weight: approximately 126Kg (8 modules per box)
- 2 Boxes / 1 Pallet
- Pallet dimensions : 1390(L) x1150(W) x901(H)mm (with boxes)

### 12.2 Packing Method

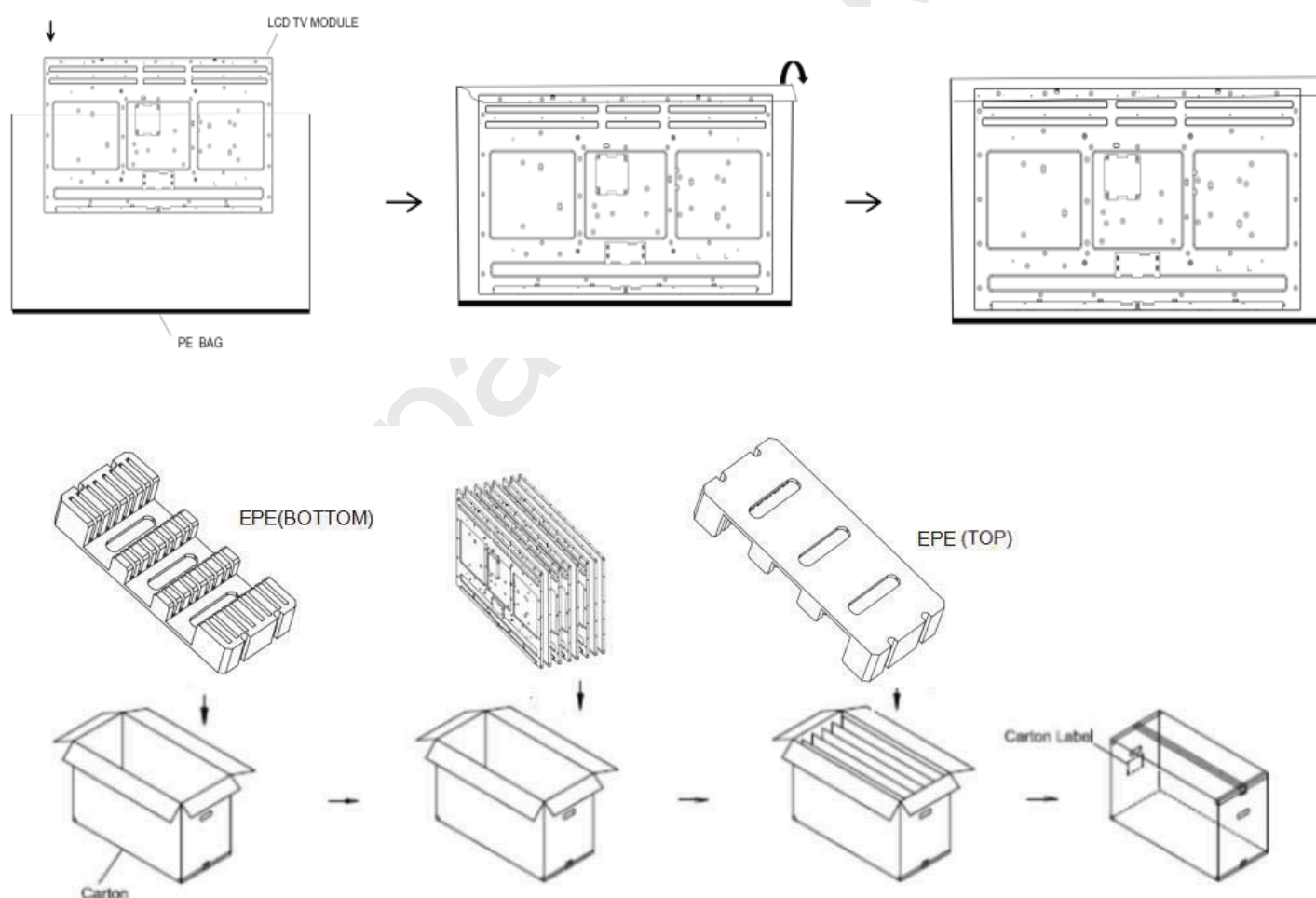

SPEC. NUMBER  
S8-65-8D-080

SPEC. TITLE  
DV550QUM-N10 Preliminary Product Specification P1

PAGE  
35 OF 40

<b>BOE</b>	<b>PRODUCT GROUP</b>	REV	ISSUE DATE
	Customer SPEC	P1	2019/08/22

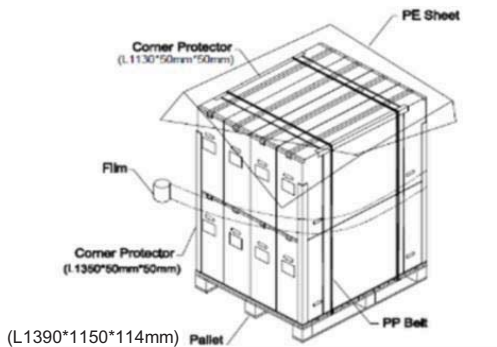

Sea/ Land Transportation

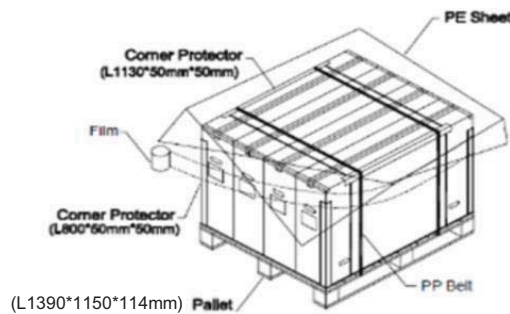

Air Transportation

### 12.3 Box Label

- Label Size : 100 mm (L) × 50 mm (W)
- Contents
  - Model : DV550QUM-N10 (FG-CODE)
  - Q`ty : 8 Module in one box.
  - Serial No. : Box Serial No.
  - Date : Packing Date
  - FG Code : FG Code of Product

• Label Picture:

**BOE** FUZHOU BOE OPTOELECTRONICS TECHNOLOGY Co.,LTD

MODEL: XXXXXXXX-XXX ① Q'TY: XXX ②

SERIAL NO: XXXXXXXXXXXXX ③ DATE: XXXX.XX.XX ④

Box ID 条形码

XXXXXXXXXXXXX ⑤ XXXX ⑥

打印内容，说明如下:

- ① FG-CODE
- ② 产品数量
- ③ Box ID, 编码规则如下
- ④ Box Packing 日期
- ⑤ 产品物料号(客户端)
- ⑥ FG-CODE 后四位

RoHS Mark

### BOX ID 编码原则

Digit	1	2	3	4	5	6	7	8	9	10	11	12	13
Code	S	L	S	A	1	6	3	D	0	0	1	A	1
Description	Products GBN		Grade	Line	Year		Month	Revision Code	Serial No.				

SPEC. NUMBER S8-65-8D-080	SPEC. TITLE DV550QUM-N10 Preliminary Product Specification P1	PAGE 36 OF 40
------------------------------	--	------------------

**BOE**

**PRODUCT GROUP**

REV

ISSUE DATE

Customer SPEC

P1

2019/08/22

**13.0 APPENDIX**

< Figure 1. Measurement Set Up >

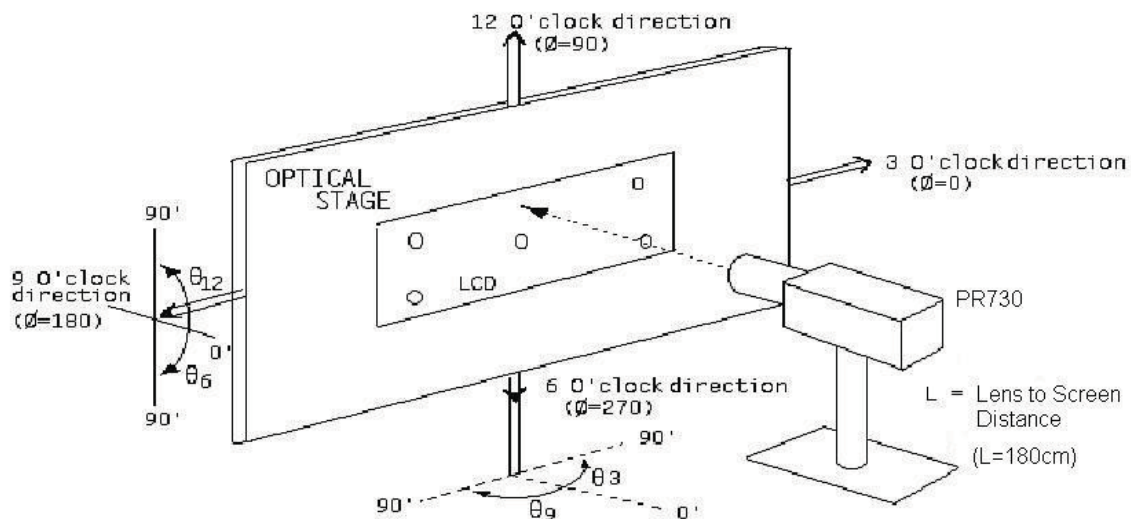

< Figure 2. Response Time Testing >

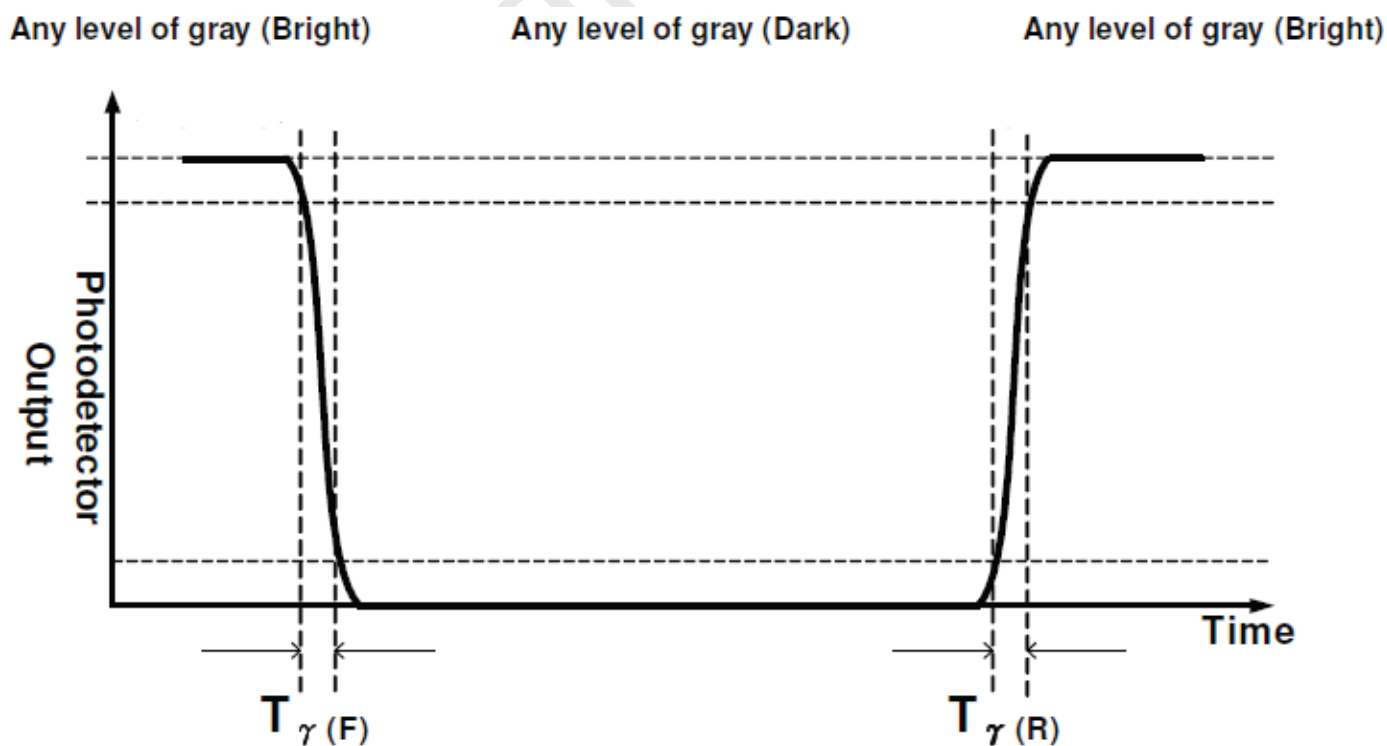

SPEC. NUMBER  
S8-65-8D-080

SPEC. TITLE  
DV550QUM-N10 Preliminary Product Specification P1

PAGE  
37 OF 40

**BOE**

**PRODUCT GROUP**

REV

ISSUE DATE

Customer SPEC

P1

2019/08/22

**13.0 APPENDIX**

< Figure 3. Point for Luminance Measure >

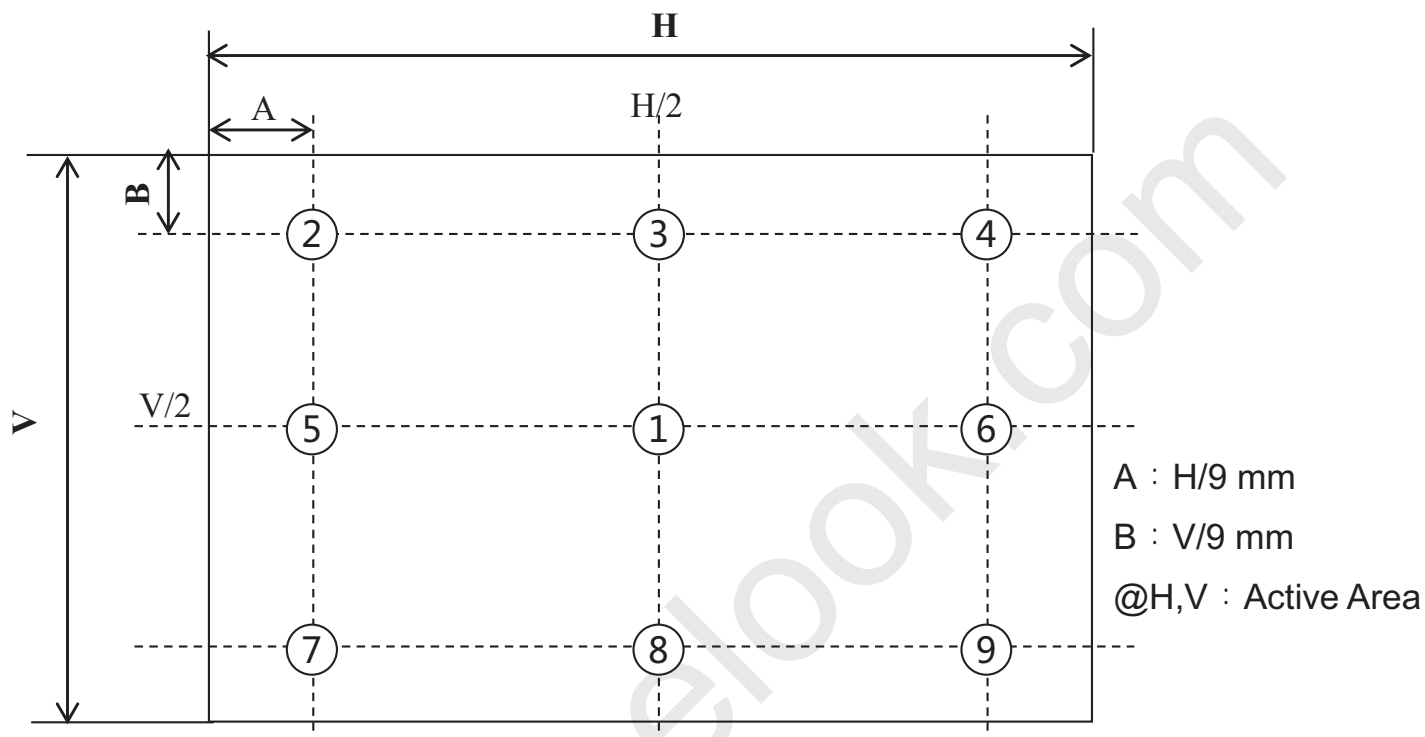

Measuring point for surface luminance & luminance variation CA-310 ,Contact method

SPEC. NUMBER  
S8-65-8D-080

SPEC. TITLE  
DV550QUM-N10 Preliminary Product Specification P1

PAGE  
38 OF 40

**BOE****PRODUCT GROUP**

REV

ISSUE DATE

Customer SPEC

P1

2019/08/22

**13.0 APPENDIX**

&lt; Figure 4. TFT-LCD Module Outline Dimensions (Front View) &gt;

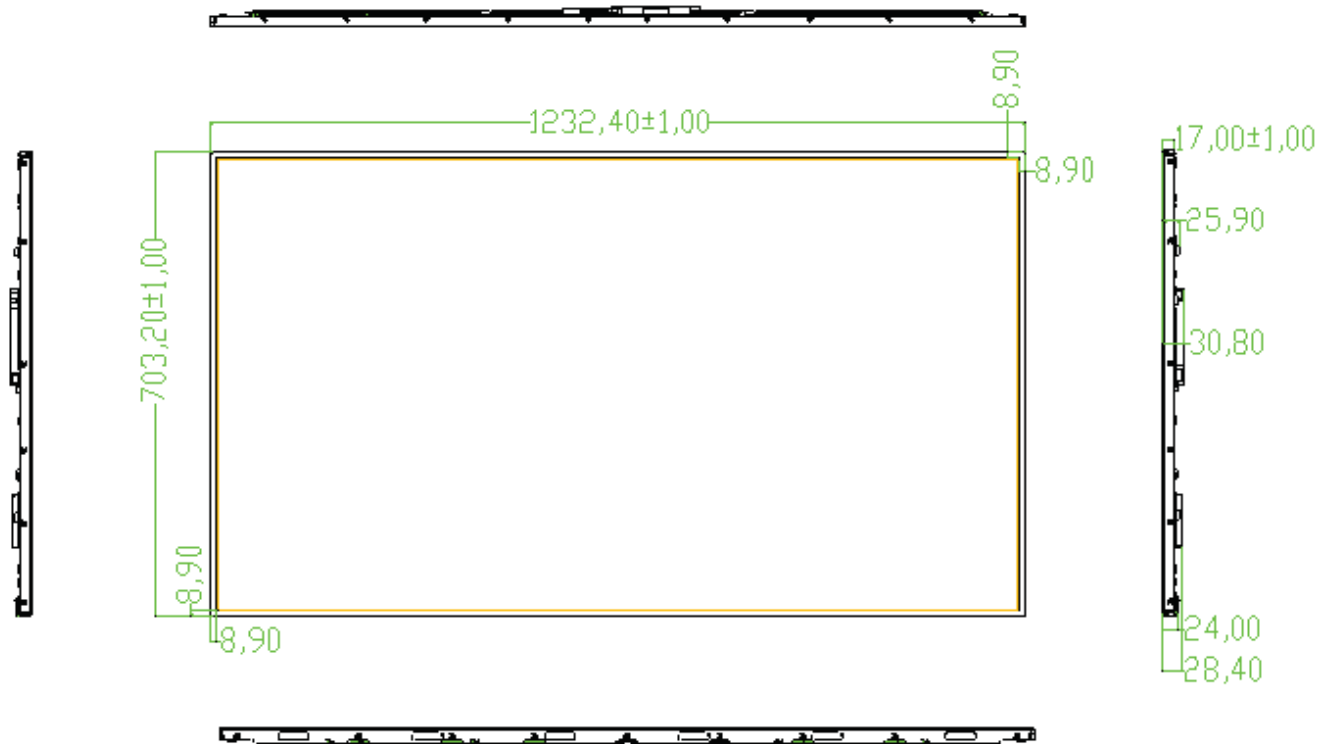

&lt; Figure 5. TFT-LCD Module Outline Dimensions (Rear View) &gt;

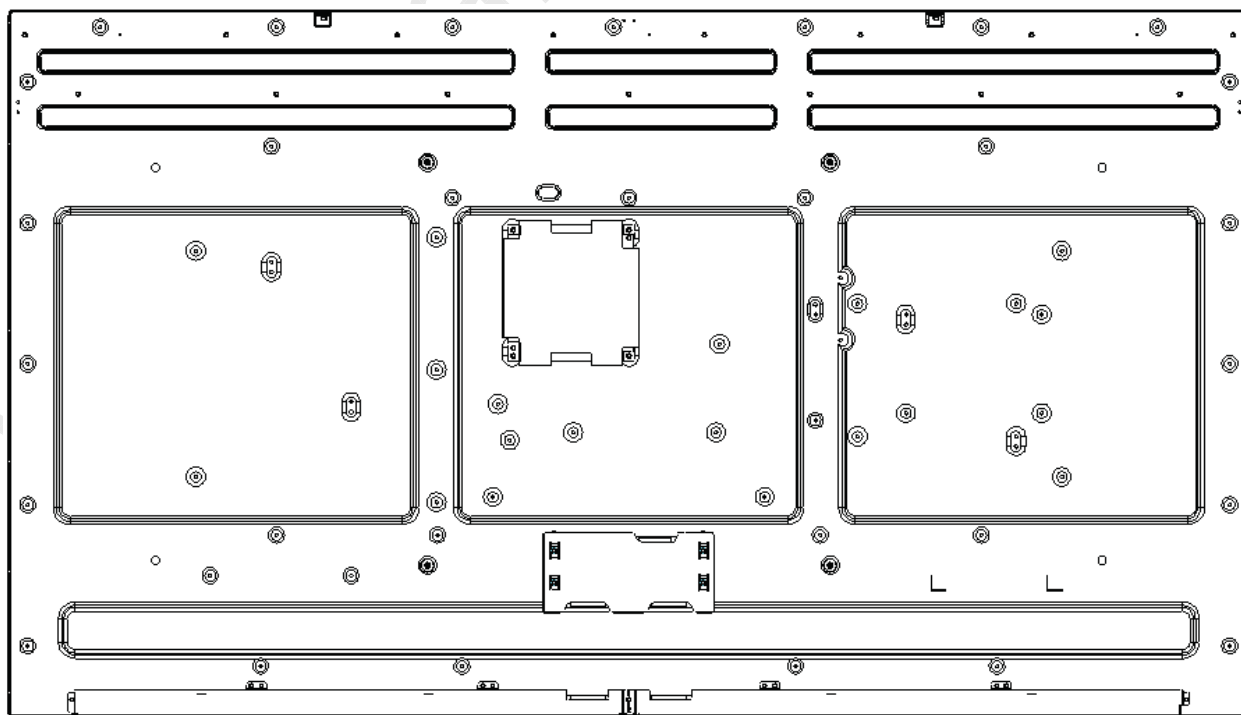
SPEC. NUMBER  
S8-65-8D-080SPEC. TITLE  
DV550QUM-N10 Preliminary Product Specification P1PAGE  
39 OF 40

**BOE****PRODUCT GROUP**

REV

ISSUE DATE

Customer SPEC

P1

2019/08/22

**13.0 APPENDIX**

(a) This Product is Reverse type display Mode

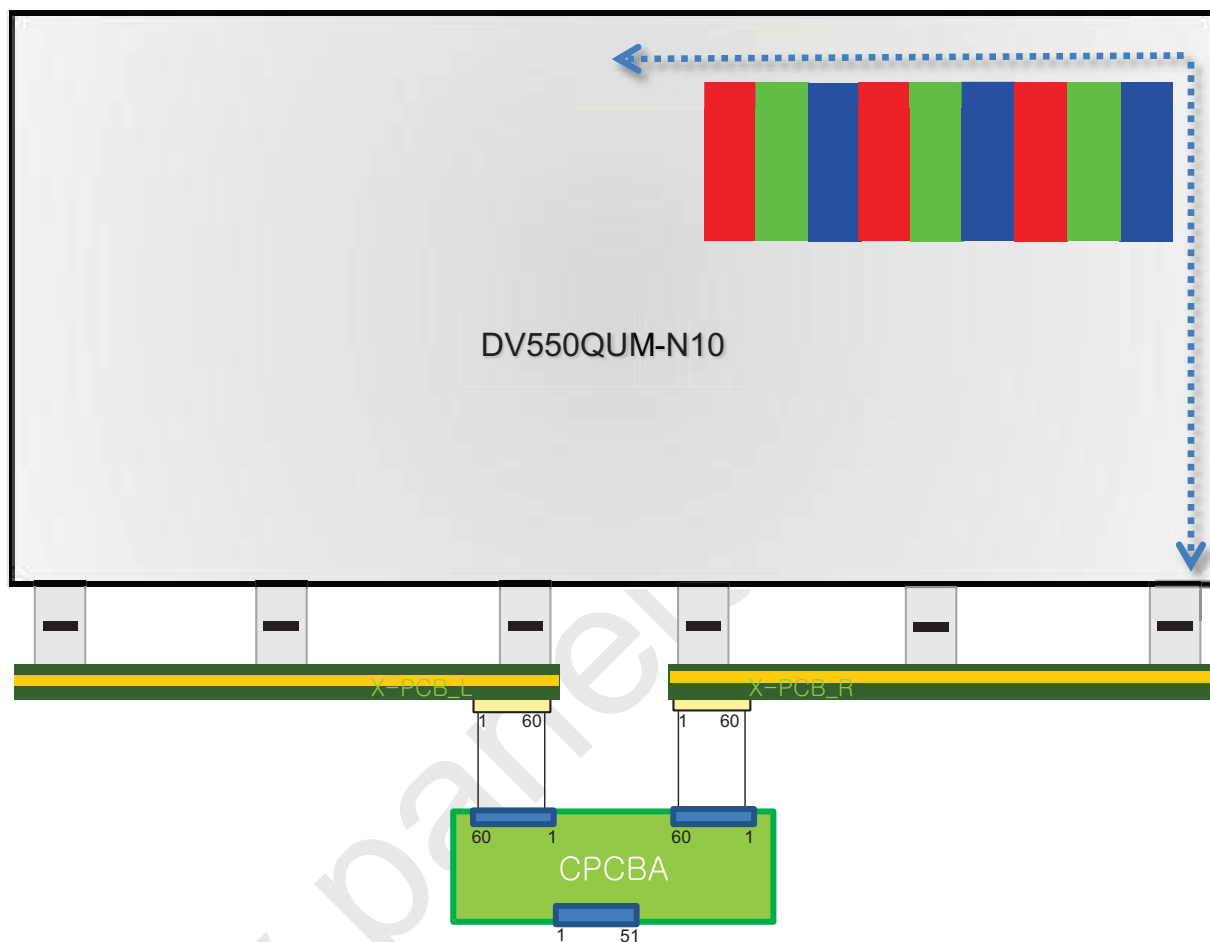

1. Panel scan direction is from top to bottom.
2. Driver data latch direction is from right to left.

SPEC. NUMBER  
S8-65-8D-080

SPEC. TITLE  
DV550QUM-N10 Preliminary Product Specification P1

PAGE  
40 OF 40